



1.0 REDUCTEURS COAXIAUX A
1.0 REDUCTORES COAXIALES A
1.0 REDUTORES COAXIAIS A

A

1.1	Caractéristiques techniques
1.2	Dénomination
1.3	Versions
1.4	Lubrification
1.5	Charges radiales et axiales
1.6	Performances réducteurs
1.7	Performances motoréducteurs
1.8	Dimensions
1.9	Languettes

<i>Características técnicas</i>
<i>Designación</i>
<i>Versiones</i>
<i>Lubricación</i>
<i>Cargas radiales y axiales</i>
<i>Prestaciones reductores</i>
<i>Prestaciones motorreductores</i>
<i>Dimensiones</i>
<i>Chavetas</i>

Características técnicas
Designação
Versões
Lubrificação
Cargas radiais e axiais
Desempenhos redutores
Desempenhos motoredutores
Dimensões
Lingüetas

B1
B2
B3
B7
B9
B11
B25
B38
B56

B



40-50-60-80-100

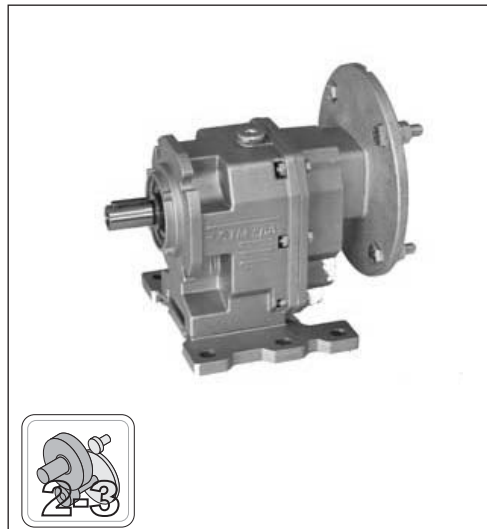

25-35-41-45



50-55-60-70-80-90
100-110-120-140

1.1 Caractéristiques techniques

La conception de cette série de réducteurs a été mise en place pour une structure monolithique extrêmement rigide, permettant d'appliquer des charges élevées sans risques de déformation, qui pourraient être préjudiciables aux performances. De plus, la forme interne particulière de sa carcasse permet de diriger le flux du lubrifiant de manière à le faire parvenir à toutes les parties en mouvement, à éviter le bruit et à favoriser l'étanchéité. Une autre nouveauté est représentée par la bride de sortie rapportée, permettant une grande souplesse d'application. Forts d'une solide expérience dans le domaine des réducteurs à engrenages coaxiaux à 2 et 3 étages, nous avons réalisé un réducteur mono-étagé : un bon rapport couple/coût pour des applications industrielles impliquant un haut nombre de tours de l'arbre lent.

1.1 Características técnicas

El diseño de esta serie de reductores ha sido fijado sobre una estructura monolítica de extraordinaria rigidez: esto permite la aplicación de cargas elevadas sin riesgo de deformación que pueda afectar al rendimiento. Por otra parte, la forma interna particular de la carcasa permite una orientación del flujo del lubricante apto para llegar a todas las partes en movimiento, para evitar el ruido y favorecer la estanqueidad. Otra novedad es la brida de salida modular que permite una gran versatilidad de aplicación. Gracias a la consolidada experiencia en el campo de los reductores con engranajes coaxiales en 2 y 3 etapas, hemos realizado el engranaje de una etapa: la relación ideal entre par y costes para aplicaciones industriales donde se requiere un elevado número de revoluciones del eje de salida.

1.1 Características técnicas

O projeto desta série de redutores foi organizado em uma estrutura monolítica de extraordinária rigidez: isto permite a aplicação de cargas elevadas sem riscos de deformação, que poderiam comprometer os seus desempenhos. Além disso, a particular forma interna da carcaça consente a orientação do fluxo de lubrificante apto a atingir todas as peças em movimento, evitando o ruído e favorecendo a vedação. Outra novidade é representada pela flange de saída mostrada, que consente uma grande versatilidade de aplicação. Graças à experiência consolidada no campo dos redutores de engrenagens coaxiais de 2 e 3 estágios, realizamos o redutor monoestágio: a justa relação de binário/custo para as aplicações industriais onde se requer um alto número de rotações do eixo de saída.



1.2 Dénomination

1.2 Designación

1.2 Designação

Maschine	Input Version	Output Version	Size	N° of Reduction	Reduction Ratio	Input Shaft	Dénomination Moteurs Designación Motores Designação motores	Shaft Diameter	Mounting positions	Position Terminal Box	WEB: Reference Designation	
00-M	01-IV	02-OV	03-SIZE	04-NOR	05-IR	07-IS		09-SD	10-MP	12-PMT		
A	M	— P P1 P2 F1 F2 F3 P/F P/F1 P/F2 P/F3	25	1	Voir les tableaux des performances Ver tablas prestaciones Veja as tabelas dos desempenhos	80B5 80B14	—	— Aucune indication diamètre standard	M1 M2 M3 M4 M5 M6	1 2 3 4 5 6 7 8	AMP 50/2 1:20.8 80B5	
			32			—	Ninguna indicación diámetro estándar	AMP 50/2 1:20.8 T 56 A 4 B5				
			35			—	Nenhuma indicação diâmetro padrão	ARP 50/2 1:20.8				
			40			—	Ø...	Diámetro orificio opcional			ACP 50/2 1:20.8 T56A4	
			41			—	Diámetro do furo opcional					
			45			—						
	R	— P P1 P2 F1 F2 F3 P/F P/F1 P/F2 P/F3	50	2	Voir les tableaux des performances Ver tablas prestaciones Veja as tabelas dos desempenhos	—	Look-CT 18 IGB D	—				
			55			—						
			60			—						
			70			—						
			80			—						
			90			—						
C	— P P1 P2 F1 F2 F3 P/F P/F1 P/F2 P/F3	100	3	Voir les tableaux des performances Ver tablas prestaciones Veja as tabelas dos desempenhos	—	Look-CT 18 IGB D	—					
		110			—							
		120			—							
		120			—							
		140			—							
		140			—							

00 M - Machine

M - Máquina

M - Máquina

**A**

01 IV - Version d'entrée

IV - Versión Entrada

IV - Versão Entrada

M	R	C	
	—		25
	—		32
	—		35
	—		40
	—		41
	—		45
		Only 55/3	50
		Only 70/3	55
		Only 90/3	60
		—	70
		—	80
		—	90
		—	100
		—	110
		—	120
		—	140

Disponible / Disponible / Disponível
 non Disponible / Non Disponible / Non Disponível

02 OV - Version Sortie

OV - Versión Salida

OV - Versão Saída

— - P - P1 - P2 - F. - P/F - P/F.

Pour plus d'informations voir B3-B4 / Para mayor información ver B3-B4 / Para mais informações, veja B3-B4

03 SIZE - Taille

SIZE - Tamaños

SIZE - Dimensão

25	32	35	40	41	45	50	55	60	70	80	90	100	110	120	140
----	----	----	----	----	----	----	----	----	----	----	----	-----	-----	-----	-----



1.2 Dénomination

02 OV - Version Sortie

1.2 Designación

OV - Versión Salida

1.2 Designação

OV - Versão Saída



Versions réducteurs
Versiones reductores
Versões redutores

AM/1 - AR/1 - AC/1

32 - 40 - 50 - 60 - 80 - 100

	AM... (IEC)	AM...	AR...	AC...
P				
F.				



Versions réducteurs
Versiones reductores
Versões redutores

AM/2-3 - AC/2-3

25 - 35 - 41 - 45

	AM... (IEC)	AM...	AC...
-			
P	<div style="border: 1px solid black; padding: 2px;">25-35-45</div> <div style="border: 1px solid black; padding: 2px; margin-top: 5px;">41</div>		
P1			
P2			
F.			
P/F.	<div style="border: 1px solid black; padding: 2px;">25-35-45</div> <div style="border: 1px solid black; padding: 2px; margin-top: 5px;">41</div>		
P1/F.			
P2/F.			



1.2 Dénomination

02 OV - Version Sortie

1.2 Designación

OV - Versión Salida

1.2 Denominação

OV - Versão Saída

Versions réducteurs
Versiones reductores
Versões redutores

AM/2-3 - AR/2-3 - AC/2-3

50 - 55 - 60 - 70 - 80 - 90 - 100 - 110 - 120 - 140

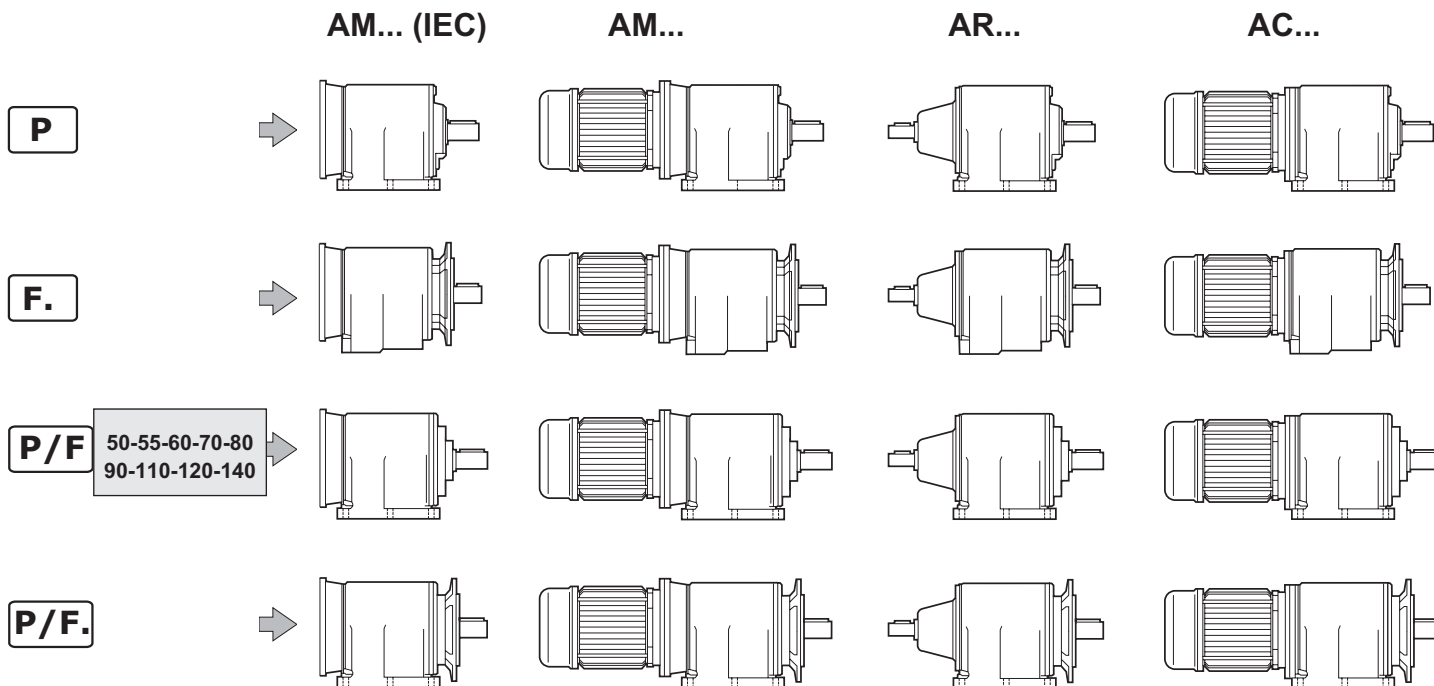

04 NOR - N° stades

NOR - No. etapas

NOR - N° fases

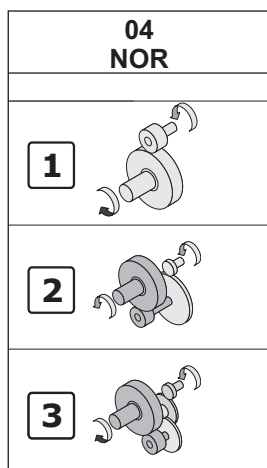

25	32	35	40	41	45	50	55	60	70	80	90	100	120	110	140
Applicabilité / Aplicación / De aplicabilidade															
-		-		-			-		-		-			-	
	-		-												
		-		-											

Disponible / Disponible / Disponível
 Non Disponible / Non Disponible / Non Disponível

05 IR- Rapport de réduction

IR - Relación de reducción

IR - Relação de redução

(Voir performances). Toutes les valeurs des rapports sont approximatives. Pour les applications qui nécessitent la valeur exacte, merci de contacter notre service technique.

(Ver prestaciones). Todos los valores de las relaciones son aproximativos. Para las aplicaciones que requieren el valor exacto, consultar con nuestro servicio técnico.

(Veja os desempenhos). Todos os valores das relações são aproximativos. Para aplicações onde se necessita do valor exato, consulte o nosso serviço técnico.



1.2 Dénomination

07 IS - Arbre d'entrée

Le tab. indique les tailles des moteurs qui peuvent être raccordés (IEC) et les dimensions arbre/bride moteur standard

Légende

11/140 (B5) : combinaisons arbre/bride standard

11/120 : combinaisons arbre/bride sur demande

Possibilités d'accouplement avec des moteurs IEC - Posibles acoplamientos con motores IEC - Possíveis acoplamentos com motores IEC

	IEC	ir (Touts / Todos / Todos)
AM 25/2	56	9/120 (B5) - 9/80 • (B14) 9/140 - 9/90
AM 25/3	63	11/140 (B5) - 11/90 (B14) 11/120 - 11/80 •
AM 32/1	80 ¹	19/200 (B5) - 19/120 (B14) 19/160 - 19/140 - 19/105 •
	71	14/160 (B5) - 14/105 (B14) 14/140 - 14/120 - 14/90 •
	63	11/140 (B5) - 11/90 • (B14) 11/160 - 11/120 - 11/105
AM 35/2	56	9/120 (B5) 9/160 - 9/140 - 9/90 •
	80	19/200 (B5) - 19/120 (B14) 19/160 - 19/140 - 19/105 • - 19/90 •
	71	14/160 (B5) - 14/105 (B14) 14/140 - 14/120 - 14/90 •
AM 35/3	63	11/140 (B5) - 11/90 • (B14) 11/160 - 11/120 - 11/105
	63	11/140 (B5) - 11/90 (B14) 11/120 - 11/80 •
AM 40/1	56	9/120 (B5) - 9/80 • (B14) 9/140 - 9/90
	100-112	28/250 (B5) - 28/160 (B14)
	90	24/200 (B5) - 24/140 (B14) 24/160 - 24/120
	80	19/200 (B5) - 19/120 (B14) 19/160 - 19/140
	71	14/160 (B5)
AM 41/2	63	11/140 (B5)
	90 ⁽¹⁾	24/200 (B5) - 24/140 (B14) - 24/160 - 24/120 - 24/105 •
	80	19/200 (B5) - 19/120 (B14) - 19/160 - 19/140 - 19/105 •
	71	14/160 (B5) - 14/105 • (B14) - 14/200 - 14/140 - 14/120 - 14/90 •
AM 41/3	63	11/140 (B5) - 11/90 • (B14) - 11/200 - 11/160 - 11/120 - 11/105 •
	71	14/160 (B5) - 14/105 (B14) - 14/140 - 14/120 - 14/90 •
	63	11/140 (B5) - 11/90 • (B14) - 11/160 - 11/120 - 11/105
AM 45/2	100-112 ⁽¹⁾	28/250 (B5) - 28/160 (B14) 28/140
	90	24/200 (B5) - 24/140 (B14) - 24/250 - 24/160 - 24/120
	80	19/200 (B5) - 19/120 (B14) - 19/160 - 19/140 - 19/105 •
	71	14/160 (B5) - 14/105 • (B14) - 14/200 - 14/140 - 14/120
AM 45/3	80	19/200 (B5) - 19/120 (B14) - 19/160 - 19/140 - 19/105 • - 19/90 •
	71	14/160 (B5) - 14/105 • (B14) - 14/200 - 14/140 - 14/120 - 14/90 •
	112	28/250 (B5) - 28/160 (B14)
AM 50/1 AM 50/2	100	28/250 (B5) - 28/160 (B14)
	90	24/200 (B5) - 24/140 (B14) 24/160 - 24/120
	80	19/200 (B5) - 19/120 (B14) 19/160 - 19/140
	71	14/160 (B5) 14/200 - 14/140 - 14/120
	63	11/140 (B5)
AM 55/2	112	28/250 (B5) - 28/160 (B14)
	100	28/250 (B5) - 28/160 (B14)
	90	24/200 (B5) - 24/140 (B14) 24/160 - 24/120
	80	19/200 (B5) - 19/120 (B14) 19/160 - 19/140
	71	14/160 (B5) 14/200 - 14/140 - 14/120
AM 50/3 AM 55/3	90	24/200 (B5) - 24/140 (B14) 24/160 - 24/120
	80	19/200 (B5) - 19/120 (B14) 19/160 - 19/140
	71	14/160 (B5)
AM 60/1 AM 60/2	63	11/140 (B5)
	132	38/300 (B5) - 38/200 (B14) - 38/250
	112	28/250 (B5) - 28/160 (B14) - 28/200 - 28/300
	100	28/250 (B5) - 28/160 (B14) - 28/200 - 28/300
	90	24/200 (B5) - 24/140 (B14) - 24/300 - 24/250 - 24/160 24/120
	80	19/200 (B5) - 19/120 (B14) - 19/160 - 19/140
71	14/160 (B5)	

1.2 Designación

IS - Eje Entrada

En la tab. se indican los tamaños de motores acoplables (IEC) junto con las dimensiones eje/brida motor estándar

Leyenda:

11/140 (B5): combinación eje/brida estándar

11/120: combinación eje/brida estándar a pedido

1.2 Denominação

IS - Eixo Entrada

Na tabela são mostradas as dimensões de motor acopláveis (IEC) junto com as dimensões de eixo/flange do motor padrão

Leyenda:

11/140 (B5): combinações eixo/flange padrão

11/120 (B5): combinações eixo/flange sob encomenda

	IEC	ir (Touts / Todos / Todos)
AM 70/2	132	38/300 (B5) - 38/200 (B14) - 38/250
	112	28/250 (B5) - 28/160 (B14) - 28/200 - 28/300
	100	28/250 (B5) - 28/160 (B14) - 28/200 - 28/300
	90	24/200 (B5) - 24/300 - 24/250
	80	19/200 (B5)
AM 60/3 AM 70/3	112	28/250 (B5) - 28/160 (B14)
	100	28/250 (B5) - 28/160 (B14)
	90	24/200 (B5) - 24/140 (B14) - 24/160 - 24/120
	80	19/200 (B5) - 19/120 (B14) - 19/160 - 19/140
AM 80/1 AM 80/2	71	14/160 (B5) - 14/200 - 14/140 - 14/120
	160	42/350 (B5) - 42/300 - 42/250
	132	38/300 (B5) - 38/350 - 38/250
	112	28/250 (B5) - 28/350 - 28/300
	100	28/250 (B5) - 28/350 - 28/300
AM 90/2	90	24/200 (B5)
	80	19/200 (B5)
	180	48/350 (B5)
	160	42/350 (B5) - 42/300 - 42/250
	132	38/300 (B5) - 38/350 - 38/250
AM 80/3 AM 90/3	112	28/250 (B5) - 28/350 - 28/300
	100	28/250 (B5) - 28/350 - 28/300
	90	24/200 (B5)
	80	19/200 (B5)
AM 100/1 AM 100/2 AM 110/2	200 [*]	55/400 (B5)
	180 [*]	48/350 (B5)
	160 [*]	42/350 (B5)
	132	38/300 (B5) - 38/200 (B14) - 38/250
	112	28/250 (B5) - 28/200 - 28/300
AM 100/3 AM 110/3	100	28/250 (B5) - 28/200 - 28/300
	132	38/300 (B5) - 28/300
	112	28/250 (B5) - 38/250
	100	28/250 (B5) - 38/250
	90	24/200 (B5)
AM 120/2 AM 140/3	225 [*]	60/450 (B5)
	200 [*]	55/400 (B5) - 55/450
	180 [*]	48/350 (B5) - 48/450 - 48/400
	160 [*]	42/350 (B5) - 42/450 - 42/400
	132	38/300 (B5) - 38/200 (B14) - 38/250
	112	28/250 (B5) - 28/200 - 28/300
AM 120/3	100	28/250 (B5) - 28/200 - 28/300
	132	38/300 (B5)
	112	28/250 (B5)
	100	28/250 (B5)
AM 140/2	90	24/200 (B5)
	250 [*]	65/550 (B5)
	225 [*]	60/450 (B5)
	200 [*]	55/400 (B5)
	180 [*]	48/350 (B5)
	160 [*]	42/350 (B5)
AM 140/3	132 [*]	38/300 (B5)
	all	voir AM 120/2 / ver AM 120/2 / veja AM 120/2

⁽¹⁾ **ATTENTION!** (Voir Paragraphe 1.12-Section A)/(Ver párrafo 1.12-Sección A)/(Veja o parágrafo 1.12-Secção A)

¹Le PAM 80 B5 dans AM 32/1 est uniquement disponible avec corps bridé

¹ El PAM 80 B5 en el AM 32/1 está disponible solo con cuerpo con brida

¹ O PAM 80 B5 no AM 32/1 só é disponível com corpo flangeado.

* Tous les PAM sont fournis avec joint ROTEX. Pour les PAM avec astérisque voir les prescriptions (pour les prescriptions de montage voir la section A paragraphe « Installation » - 1.12)

* Todos los PAM se suministran con acoplamiento ROTEX. Para los PAM marcados con asterisco ver las indicaciones (para las indicaciones de montaje ver sección A párrafo "Instalación" - 1.12)

* Todos os PAM são fornecidos com união ROTEX. Para os PAM marcados com asterisco, veja as prescrições (para as prescrições de montagem, veja a seção A parágrafo "Instalação" - 1.12)



Position de la plaque à bornes - 12 - PMT - Page B6
Posición caja de bornes - Ver - 12 - PMT - Página B6
Posição da placa de bornes - Veja - 12 - PMT - Página B6

Désignation moteur électrique
En cas de demande d'un motorréducteur avec un moteur, il est nécessaire d'indiquer la désignation de ce dernier.
À cet égard, consulter notre catalogue des moteurs électriques Electronic Line.

Designación motor eléctrico
Si se solicita un motorreductor equipado con motor, es necesario indicar la designación de este último.
Para ello consultar nuestro catálogo de motores eléctricos Electronic line.

Designação do motor eléctrico
Se for pedido um motorreductor com motor, é necessário indicar a designação deste último.
Para tal fim, consulte o nosso catálogo dos motores eléctricos Eletronic Line.



1.2 Dénomination

1.2 Designación

1.2 Denominação

07 IS - Arbre d'entrée

IS - Eje Entrada

IS - Eixo Entrada

— Aucune indication = diamètre standard

— Ninguna indicación = diámetro estándar

— Nenhuma indicação = diâmetro padrão;

AR / 1		32	40	50	60	80	100				
		(Ø 16)	(Ø 16)	(Ø 16)	(Ø 19)	(Ø 24)	(Ø 28)				
AR / 2		50	55	60	70	80	90	100	110	120	140
		(Ø 16)	(Ø 16)	(Ø 19)	(Ø 19)	(Ø 24)	(Ø 24)	(Ø 28)	(Ø 28)	(Ø 38)	(Ø 48)
AR / 3		50	55	60	70	80	90	100	110	120	140
		(Ø 16)	(Ø 16)	(Ø 19)	(Ø 19)	(Ø 24)	(Ø 24)	(Ø 28)	(Ø 28)	(Ø 38)	(Ø 38)

09 SD - Diamètre arbre

SD - Diámetro Eje

SD - Diâmetro eixo

— Aucune indication = diamètre standard; diamètre optionnel = voir tableau.

— Ninguna indicación = diámetro estándar; diámetro opcional = ver tabla.

— Nenhuma indicação = diâmetro padrão diâmetro opcional = veja a tabela.

A... / 1		32	40	50	60	80	100									
		Standard	—	—	—	—	—	—								
		Optional	Ø 14	Ø 20	Ø 25	Ø 30	Ø 40	Ø 50								
A... / 2 A... / 3		25	35	41	45	50	55	60	70	80	90	100	110	120	140	
		Standard	—	—	—	—	—	—	—	—	—	—	—	—	—	—
		Optional	Ø 14	Ø 19 Ø 20	Ø 19 Ø 25	Ø 24 Ø 30	Ø 24 Ø 30	Ø 32	Ø 28 Ø 35	not available	Ø 38	(Ø 48)	Ø 48	not available	not available	Ø 80

10 MP - Positions de montage

MP - Posiciones de montaje

MP - Posições de montagem

[M2, M3, M4, M5, M6] Positions de montage avec indication des bouchons de niveau, de remplissage et de vidange ; sauf autrement spécifié, la position M1 est à considérer standard (voir par. 1.4)

[M2, M3, M4, M5, M6] Posiciones de montaje con indicaciones de los tapones de nivel, carga y descarga; si no se especifica, se considera estándar la posición M1 (ver párr. 1.4)

Montageposition [M2, M3, M4, M5, M6] Posições de montagem com a indicação dos tampos de nível, carga e descarga; caso não for especificado, considere padrão a posição M1 (veja o par. 1.4)

11 OPT-ACC. - Options

OPT-ACC - Opciones

OPT-ACC. - Opções

voir section A-1.12 ver sección A-1.12 veja secção A-1.12	OPT.	OPT	Matériau des bagues d'étanchéité	Materiales de los anillos de estanqueidad	Material dos anéis de vedação
		OPT1	État de fourniture huile	Estado suministro aceite	Estado de fornecimento do óleo
		OPT2	Peinture	Pintura	Pintura

12 PMT - Positions de la Plaque à bornes

PMT - Position Terminal Box

PMT - Montagposition Klemmenkasten

[2, 3, 4] Position de la plaque à bornes du moteur si différente de celle standard (1)

[2, 3, 4] Posición de la caja de bornes del motor si es diferente a la estándar (1).

[2, 3, 4] Posição da placa de bornes do motor, se for diversa da padrão (1).

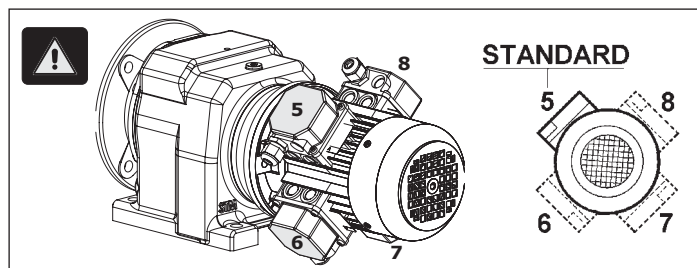
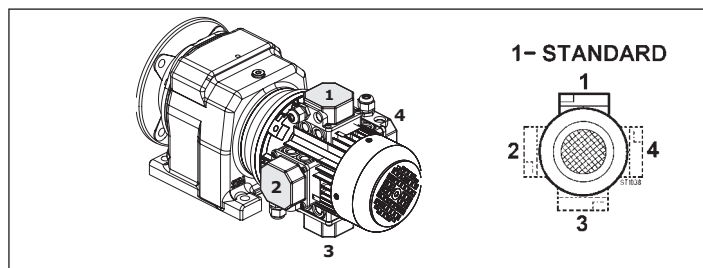

N.B.
La configuration standard de la bride de fixation moteur prévoit 4 trous à 45°.

N.B.
La configuración estándar de la brida de conexión al motor prevé 4 orificios de 45°.

OBS.
A configuração padrão da flange de conexão ao motor prevê 4 furos a 45°.

Pour les brides marquées du symbole (•) (voir page B5), les trous de fixation moteur sont disposés en parcours croisé (exemple +). Il s'avère donc nécessaire d'évaluer l'encombrement de la plaque à bornes du moteur qui sera installée car elle sera orientée à 45° par rapport aux axes. Pour le choix de la position de la plaque à bornes par rapport aux axes, se référer au schéma suivant (où la position 5 est celle standard) :

Para las bridas marcadas con el símbolo (•) (ver página B5) los orificios para la fijación al motor se disponen en cruz (ejemplo +). Por lo tanto, es conveniente evaluar la dimensión de la caja de bornes del motor que se instalará ya que la misma se orientará a 45° con respecto a los ejes. Para la elección de la posición de la caja de bornes con respecto a los ejes, consultar el esquema a continuación (donde la posición 5 es la posición estándar):

Para flanges marcadas com o símbolo (•) (veja a página B5) os furos para fixagem ao motor são dispostos em cruz (exemplo +). Por isso, é oportuno medir a dimensão da placa de bornes do motor que será instalada, enquanto esta deverá estar a 45° dos eixos. Para escolher a posição da placa de bornes em relação aos eixos, veja o esquema seguinte (no qual a posição 5 é a padrão):



1.4 Lubrification

1.4 Lubricación

1.4 Lubrificação



Positions de montage
Posiciones de montaje
Posições de montagem



▽ Remplissage / Carga / Carga
 ● Niveau / Nivel / Nivel
 ▼ Vidange / Descarga / Descarga

▽ Remplissage / Carga / Carga
 ● Niveau / Nivel / Nivel
 ▼ Vidange / Descarga / Descarga

Positions de montage - Posiciones de montaje - Posições de montagem			
AR AM AC		Positions Posiciones Posições	Prescriptions à indiquer au moment de la commande Indicaciones para la fase de pedido Prescrições a indicar na fase de ordem
	32	M1-M2 M3-M4 M5-M6	Pas nécessaire Non necesaria Não necessária
	40		Nécessaire Necesaria nécessária
	50		
	60		
	80		
100			

Positions de montage - Posiciones de montaje - Posições de montagem			
AR AM AC		Positions Posiciones Posições	Prescriptions à indiquer au moment de la commande Indicaciones para la fase de pedido Prescrições a indicar na fase de ordem
	25	M1-M2 M3-M4 M5-M6	Pas nécessaire Non necesaria Não necessária
	35 41 45 50 55 60 70 45 55 70 90 100 110 120 140		Nécessaire Necesaria Necessária

PLAQUETTE - RÉDUCTEUR

PAS NÉCESSAIRE

Toujours indiquée sur la plaquette du réducteur la position de montage « M1 ».

NÉCESSAIRE

La position demandée est indiquée sur la plaquette du réducteur del riduttore

TARJETA - REDUCTOR

NO NECESARIA

Se indica siempre en la tarjeta del reductor la posición de montaje "M1".

NECESARIA

La posición solicitada se indica en la tarjeta del reductor

PLACA - REDUTOR

NÃO NECESSÁRIA

Indicada sempre na placa do redutora posição de montagem "M1".

NECESSÁRIA

A posição pedida está indicada na placa do redutor



1.4 Lubrification

1.4 Lubricación

1.4 Lubrificação

Lub	Quantité de lubrifiant / Cantidad de lubricante / Quantidade de lubrificante-Kg								OPT1	Bouchons- Tapones - Tampos		
			M1	M2	M3	M4	M5	M6		N°	Diameter	Type
AR AM AC	32	/1	0.100	0.100	0.100	0.100	0.100	0.100	INOIL_STD	1	1/8"	
	40	/1	0.160	0.270	0.180	0.270	0.160	0.160		1	1/4"	
	50	/1	0.300	0.300	0.200	0.300	0.200	0.200		1	1/4"	
	60	/1	0.470	0.640	0.570	0.750	0.570	0.570		1	3/8"	
	80	/1	1.050	1.050	1.350	1.650	1.400	1.400			3/8"	
	100	/1	2.500	3.000	3.000	3.300	3.000	3.000	OUTOIL	4	3/8"	
AR AM AC	Quantité de lubrifiant / Cantidad de lubricante / Quantidade de lubrificante-Kg								OPT1	Bouchons - Tapones - Tampos		
			M1	M2	M3	M4	M5	M6		N°	Diameter	Type
	25	/2 /3	0.120						INOIL_STD	1	1/8"	
	35	/2	0.150	0.200	0.200	0.200	0.150	0.150		1	12.1	
	35	/3	0.250	0.250	0.325	0.250	0.200	0.200		1	12.1	
	41	/2	0.290	0.290	0.240	0.300	0.200	0.200		1	12.1	
	41	/3	0.300	0.300	0.350	0.350	0.260	0.260		1	12.1	
	45	/2	0.350	0.350	0.400	0.400	0.350	0.350		1	12.1	
	45	/3	0.400	0.400	0.630	0.600	0.400	0.400		1	12.1	
	50	/2 /3	0.950	0.950	1.350	1.350	0.950	0.950		1	1/4"	
	55	/2	1.600	2.000	2.500	2.700	1.600	1.600		1	1/4"	
	55	/3	1.600	2.000	2.700	2.700	1.600	1.600		1	1/4"	
	60	/2 /3	1.550	1.550	2.610	2.150	1.550	1.550	OUTOIL	4	3/8"	
	70	/2	2.200	3.300	3.600	3.900	2.600	2.800		5	1/4"	
	70	/3	2.200	3.300	4.100	3.900	2.600	2.800		5	1/4"	
	80	/2 /3	2.600	2.600	4.850	4.440	2.600	2.600		4	1/2"	
	90	/2 /3	5.000	5.900	7.800	6.700	5.900	5.900		4	3/8"	
	100	/2 /3	5.550	5.550	9.600	9.600	5.550	5.550		4	1/2"	
	110	/2 /3	8.700	11.20	12.10	11.90	8.600	9.600		4	1/2"	
	120	/2 /3	10.00	10.00	16.50	16.50	10.00	10.00		4	1/2"	
140	/2	16.00	19.00	21.00	25.50	16.00	19.00	7		1/2"		
140	/3	16.00	19.00	26.00	25.50	16.00	19.00	7		1/2"		

Quantités à titre indicatif ; durant le remplissage, voir le repère de niveau.

Cantidades indicativas; durante la reposición, observar el testigo de nivel.

Quantidades indicativas; durante o abastecimento, respeite o indicador de nível.

Attention ! :
Le bouchon reniflard est inclus uniquement dans les réducteurs qui ont plusieurs bouchons huile

¡ Atención ! :
El tapón de alivio se suministra solo en los reductores que tienen más de un tapón de aceite

Atenção!
O tampo de ventilação só está anexo nos reductores que possuem mais de um tampo de óleo

Remarque : Si lors de la commande la position de montage est omise, le réducteur sera fourni avec les bouchons prédisposés pour la position M1.

Nota: Si en la fase de pedido, se omite la posición de montaje, el reductor se suministrará con los tapones predispuestos para la posición M1.

Nota: Se na fase de ordem a posição de montagem for omitida, o reductor será fornecido com os tampos preparados para a posição M1.

Toute fourniture avec des prédispositions des bouchons différentes de celle indiquée dans le tableau sont à convenir.

Los eventuales suministros con predisposiciones de los tapones diferentes a la indicada en la tabla, deberán ser acordados.

Eventuais fornecimentos com preparações dos tampos diferentes da indicada na tabela, deverão ser concordadas.



1.5 Charges radiales et axiales

Quand la transmission du mouvement se fait au moyen de mécanismes qui engendrent des charges radiales sur l'extrémité de l'arbre, il est nécessaire de vérifier que les valeurs résultantes n'excèdent pas celles indiquées dans les tableaux.

Le Tab. 2.3 indique les valeurs des charges radiales admissibles pour l'arbre côté entrée (Fr_1). Comme charge axiale admissible simultanée on a:

$$Fa_1 = 0.2 \times Fr_1$$

1.5 Cargas radiales y axiales

Quando la transmisión del movimiento se realiza por medio de mecanismos que generan cargas radiales en la extremidad del eje, es necesario verificar que los valores resultantes no excedan los indicados en las tablas.

En la Tab. 2.3 se indican los valores de las cargas radiales admisibles para el eje veloz (Fr_1). Como carga axial admisible contemporánea se tiene:

$$Fa_1 = 0.2 \times Fr_1$$

1.5 Cargas radiais e axiais

Se a transmissão de movimento acontece por mecanismos que gerem cargas radiais na extremidade do eixo, controle para que os valores resultantes não excedam aos das tabelas.

Na Tab. 2.3 são indicados os valores das cargas radiais admissíveis para o eixo rápido (Fr_1). A carga axial contemporânea admissível será:

$$Fa_1 = 0.2 \times Fr_1$$



AR/1

Tab. 2.3

n_1 min ⁻¹	Fr_1 (N)					
	AR../1					
	32	40	50	60	80	100
2800	170	320	430	520	600	1000
1400	220	400	550	700	800	1200
900	250	450	600	800	920	1300
500	300	500	850	1100	1300	1500



**AR/2
AR/3**

n_1 min ⁻¹	Fr_1 (N)																	
	AR																	
	25	35	41	45	40	50	55/2	55/3	60	70/2	70/3	80	90	100	110	120	140/2	140/3
2800	—	—	—	—	320	430	700	430	520	800	520	600	600	1000	1000	1250	2800	1250
1400	—	—	—	—	400	550	900	550	700	1000	700	800	800	1200	1200	1500	3000	1500
900	—	—	—	—	450	600	1100	600	800	1200	800	920	920	1300	1300	1600	3500	1600
500	—	—	—	—	500	850	1200	850	1100	1400	1100	1300	1300	1500	1500	1800	3800	1800

* Demander au Service Technique / Solicitar a la Oficina Técnica. / Solicitar ao Departamento Técnico

Le Tab. 2.4 indique les valeurs des charges radiales admissibles pour l'arbre côté sortie (Fr_2). Comme charge axiale admissible simultanée on a:

$$Fa_2 = 0.2 \times Fr_2$$

En la Tab. 2.4 se indican los valores de las cargas radiales admisibles para el eje lento (Fr_2). Como carga axial admisible contemporánea se tiene:

$$Fa_2 = 0.2 \times Fr_2$$

Na Tab. 2.4 são indicados os valores das cargas radiais admissíveis para o eixo lento (Fr_2). A carga axial contemporânea admissível será:

$$Fa_2 = 0.2 \times Fr_2$$

Tab. 2.4



AR/1

n_2 min ⁻¹	Fr_2 (N)					
	AR - AM - AC					
	32	40	50	60	80	100
2400	-	600	1250	1350	1900	2500
1850	-	650	1250	1450	2100	2800
1250	530	700	1500	1650	2450	3000
1100	570	720	1500	2000	2450	3500
830	630	750	1500	2300	2600	3600
630	700	850	1800	2400	2900	3700
500	700	950	2000	2600	3400	3800
400	740	1000	2200	2900	3800	3900
300	880	1150	2300	3000	4200	4200
250	970	1250	2500	3400	4500	4500
200	1020	1370	2500	3800	5000	5500
160	1070	1500	2500	3800	5500	6500
130	1200	1500	2500	3800	6000	7500
100	1260	1500	2500	3800	6000	8500
80	1320	1500	2500	3800	6000	8500
> 70	1420	1500	2500	3800	6000	8500



Tab. 2.5



AR/2
AR/3
AM/2
AM/3
AC/2
AC/3

n_2 min^{-1}	Fr_2 (N)													
	AR - AM - AC													
	25	35	41	45	50	55	60	70	80	90	100	110	120	140
1000	420	450	580	665	750	—	1100	—	2000	—	3800	4000	4500	—
700	540	580	750	875	1000	1100	1500	1800	2500	4000	5000	5400	5800	—
500	650	700	900	1050	1200	1300	1800	2300	3000	5000	6000	6800	7000	—
350	650	740	1100	1250	1400	1500	2300	3500	3700	6000	7000	8000	8200	15000
250	650	800	1300	1550	1800	2000	2600	4000	4500	7000	8200	9000	9500	16000
200	650	850	1500	1850	2200	2400	3300	5000	6000	8000	9000	10000	10000	16000
150	650	930	1600	2300	3000	3200	4000	5500	7500	9000	10000	11500	11500	20000
100	650	1000	1700	2550	3400	3500	4500	6000	8300	10000	11500	13000	12500	20000
80	650	1050	1850	2775	3700	3800	5000	6500	9000	11000	12000	13000	13500	24000
60	650	1100	1900	2900	3900	4500	5400	7000	9600	12000	13000	14000	15000	26000
30	650	1400	2300	3200	4100	5500	6000	8000	10000	13000	14000	16000	21000	30000
< 15	650	1800	2700	3500	4300	6000	6500	9000	11000	14000	15000	18000	25000	32000

Les charges radiales indiquées dans les tableaux sont appliquées à mi-extension de l'arbre et elles se réfèrent aux réducteurs agissant avec facteur de service 1. Des valeurs intermédiaires relatives à des vitesses qui ne sont pas indiquées peuvent être obtenues par interpolation en considérant que Fr_1 à 500 min^{-1} et Fr_2 à 14 min^{-1} représentent les charges maximums admises. Pour les charges qui n'agissent pas sur la ligne médiane de l'arbre côté sortie ou côté entrée on a:

à 0.3 de l'extension:

$$Fr_x = 1.25 \times Fr_{1-2}$$

à 0.8 de l'extension:

$$Fr_x = 0.8 \times Fr_{1-2}$$

Las cargas radiales indicadas en las tablas se entienden aplicadas en la mitad de la saliente del eje y se refieren a los reductores que operan con factor de servicio 1. Valores intermedios relativos a velocidades no indicadas se pueden obtener por interpolación, considerando que Fr_1 a 500 min^{-1} y Fr_2 a 14 min^{-1} representan las cargas máximas admitidas. Para las cargas que no operan en el centro del eje lento o veloz se tiene:

a 0.3 de la saliente:

$$Fr_x = 1.25 \times Fr_{1-2}$$

a 0.8 de la saliente:

$$Fr_x = 0.8 \times Fr_{1-2}$$

As cargas radiais indicadas nas tabelas são aplicadas na metade da saliência do eixo e referem-se aos redutores operantes com fator de serviço 1.

Valores intermediários relativos à velocidade não listados podem ser obtidos por interpolação, considerando que Fr_1 a 500 min^{-1} e Fr_2 a 14 min^{-1} representam as cargas máximas admitidas.

Para cargas não agem no centro do eixo lento ou rápido tem-se:

a 0.3 da saliência:

$$Fr_x = 1.25 \times Fr_{1-2}$$

a 0.8 da saliência:

$$Fr_x = 0.8 \times Fr_{1-2}$$

Tab. 2.6

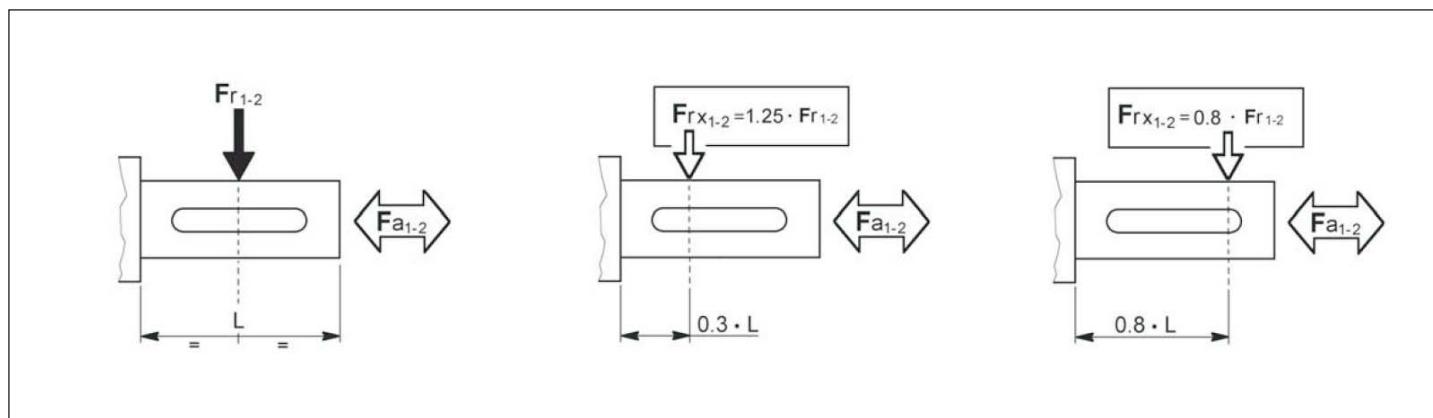



1.6 Performances réducteurs AR

1.6 Prestaciones reductores AR

1.6 Desempenhos redutores AR

AR 25/2



1.8

ir	n ₁ = 2800 min ⁻¹				n ₁ = 1400 min ⁻¹				n ₁ = 900 min ⁻¹				n ₁ = 500 min ⁻¹				IEC
	n ₂	T _{2M}	P	RD	n ₂	T _{2M}	P	RD	n ₂	T _{2M}	P	RD	n ₂	T _{2M}	P	RD	
	min ⁻¹	Nm	kW	%	min ⁻¹	Nm	kW	%	min ⁻¹	Nm	kW	%	min ⁻¹	Nm	kW	%	
3.4	819	12	1.1	95	409	12	0.55	95	263	13	0.38	95	146	16	0.26	95	56 (B5 - B14) 63 (B5 - B14)
3.9	716	12	0.96	95	358	12	0.48	95	230	13	0.33	95	128	16	0.23	95	
4.8	579	12	0.78	95	289	12	0.39	95	186	13	0.27	95	103	16	0.18	95	
5.6	498	12	0.67	95	249	12	0.33	95	160	13	0.23	95	89	16	0.16	95	
7.2	389	12	0.52	95	194	12	0.26	95	125	13	0.18	95	69	16	0.12	95	
8.7	324	12	0.44	95	162	12	0.22	95	104	13	0.15	95	58	16	0.10	95	
9.0	310	12	0.42	95	155	14	0.24	95	100	14	0.15	95	55	14	0.09	95	
10.5	267	13	0.38	95	133	14	0.21	95	86	14	0.13	95	48	14	0.07	95	
13.4	208	13	0.30	95	104	15	0.17	95	67	15	0.11	95	37	15	0.06	95	
16.2	173	13	0.25	95	87	15	0.14	95	56	15	0.09	95	31	15	0.05	95	
17.9	157	14	0.24	95	78	15	0.13	95	50	15	0.08	95	28	15	0.05	95	

AR 25/3



1.8

ir	n ₁ = 2800 min ⁻¹				n ₁ = 1400 min ⁻¹				n ₁ = 900 min ⁻¹				n ₁ = 500 min ⁻¹				IEC
	n ₂	T _{2M}	P	RD	n ₂	T _{2M}	P	RD	n ₂	T _{2M}	P	RD	n ₂	T _{2M}	P	RD	
	min ⁻¹	Nm	kW	%	min ⁻¹	Nm	kW	%	min ⁻¹	Nm	kW	%	min ⁻¹	Nm	kW	%	
18.9	148	15	0.25	93	74	19	0.16	93	48	22	0.12	93	26	22	0.07	93	56 (B5 - B14) 63 (B5 - B14)
23.4	120	15	0.20	93	60	19	0.13	93	38	22	0.10	93	21	22	0.05	93	
27.2	103	15	0.17	93	51	20	0.12	93	33	22	0.08	93	18	22	0.05	93	
31.9	88	18	0.18	93	44	17	0.08	93	28	17	0.05	93	16	17	0.03	93	
35.3	79	15	0.13	93	40	17	0.08	93	25	17	0.05	93	14	17	0.03	93	
41.8	67	18	0.14	93	33	22	0.08	93	22	22	0.05	93	12	22	0.03	93	
50.7	55	16	0.10	93	28	18	0.06	93	18	18	0.04	93	10	18	0.02	93	
59.6	47	17	0.09	93	23	19	0.05	93	15	19	0.03	93	8	19	0.02	93	
64.9	43	17	0.08	93	22	19	0.05	93	14	19	0.03	93	8	19	0.02	93	
78.0	36	17	0.07	93	18	20	0.04	93	12	20	0.03	93	6	20	0.01	93	
86.2	32	18	0.07	93	16	20	0.04	93	10	20	0.02	93	6	20	0.01	93	

Pt _N [kW]	Tous les rapports / Todas las relaciones / Todas as relações	
	25/2	3.0
	25/3	2.3

N.B. Le réducteur grandeur 25 est fourni exclusivement dans la configuration motoréducteur ou réducteur IEC.

Nota: El reductor de medida 25 se suministra exclusivamente en la configuración motorreductor o reductor predisposto IEC.

OBS. O redutor de dimensão 25 é fornecido exclusivamente na configuração motoredutor ou redutor predisposto IEC.



1.6 Performances réducteurs AR

1.6 Prestaciones reductores AR

1.6 Desempenhos redutores AR

AR 32/1 2.1

ir	n ₁ = 2800 min ⁻¹				n ₁ = 1400 min ⁻¹				n ₁ = 900 min ⁻¹				n ₁ = 500 min ⁻¹				IEC
	n ₂	T _{2M}	P	RD	n ₂	T _{2M}	P	RD	n ₂	T _{2M}	P	RD	n ₂	T _{2M}	P	RD	
	min ⁻¹	Nm	kW	%	min ⁻¹	Nm	kW	%	min ⁻¹	Nm	kW	%	min ⁻¹	Nm	kW	%	
1.8	1585	14.5	2.5	97	792	21.7	1.9	97	509	21.8	1.2	97	283	21.8	0.7	97	80 * (B5 - B14)
2.1	1350	14.9	2.2	97	675	22.6	1.7	97	434	22.7	1.1	97	241	22.8	0.6	97	
2.5	1139	16.1	2.0	97	569	23.7	1.5	97	366	23.8	0.9	97	203	23.8	0.5	97	71 (B5 - B14)
3.0	948	17.4	1.8	97	474	25.0	1.3	97	305	25.1	0.8	97	169	25.1	0.5	97	
3.4	831	17.6	1.6	97	416	25.9	1.2	97	267	25.9	0.7	97	148	25.9	0.4	97	63 (B5 - B14)
3.9	721	17.8	1.4	97	361	25.8	1.0	97	232	26.0	0.7	97	129	26.0	0.4	97	
4.5	618	17.8	1.2	97	309	26.5	0.9	97	199	26.5	0.6	97	110	26.5	0.3	97	56 (B5)
5.3	528	19.1	1.1	97	264	26.8	0.8	97	170	26.8	0.5	97	94	26.9	0.3	97	
6.5	434	16.9	0.8	97	217	20.9	0.5	97	139	22.3	0.3	97	77	24.3	0.2	97	

* Le PAM 80 B5 est disponible uniquement avec corps bridé

* El PAM 80 B5 está disponible sólo con cuerpo con brida

* O PAM 80 B5 é disponível apenas com corpo com flange.

AR 35/2 2.6

ir	n ₁ = 2800 min ⁻¹				n ₁ = 1400 min ⁻¹				n ₁ = 900 min ⁻¹				n ₁ = 500 min ⁻¹				IEC
	n ₂	T _{2M}	P	RD	n ₂	T _{2M}	P	RD	n ₂	T _{2M}	P	RD	n ₂	T _{2M}	P	RD	
	min ⁻¹	Nm	kW	%	min ⁻¹	Nm	kW	%	min ⁻¹	Nm	kW	%	min ⁻¹	Nm	kW	%	
3.4	822	32	2.85	95	411	35	1.58	95	264	39	1.12	95	147	42	0.68	95	80 (B5 - B14)
4.0	696	34	2.62	95	348	38	1.45	95	224	42	1.03	95	124	46	0.63	95	
4.7	596	36	2.36	95	298	40	1.31	95	192	44	0.93	95	106	48	0.57	95	71 (B5 - B14)
5.4	517	36	2.05	95	259	40	1.14	95	166	44	0.80	95	92	48	0.49	95	
6.3	443	36	1.75	95	221	40	0.97	95	142	44	0.69	95	79	48	0.42	95	63 (B5 - B14)
7.3	381	41	1.70	95	191	45	0.94	95	123	50	0.67	95	68	54	0.41	95	
8.7	323	45	1.60	95	162	50	0.89	95	104	52	0.59	95	58	60	0.38	95	56 (B5 - B14)
10.1	277	45	1.37	95	138	50	0.76	95	89	53	0.52	95	49	60	0.33	95	
11.7	240	45	1.19	95	120	50	0.66	95	77	54	0.46	95	43	60	0.28	95	56 (B5 - B14)
13.6	205	45	1.02	95	103	50	0.56	95	66	55	0.40	95	37	60	0.24	95	
15.7	178	50	0.97	95	89	55	0.54	95	57	55	0.35	95	32	60	0.21	95	56 (B5 - B14)
18.1	154	50	0.84	95	77	55	0.47	95	50	55	0.30	95	28	60	0.18	95	
21.3	131	50	0.71	95	66	55	0.40	95	42	60	0.28	95	23	60	0.15	95	56 (B5 - B14)
25.2	111	51	0.63	95	56	57	0.35	95	36	60	0.24	95	20	60	0.13	95	
28.7	98	54	0.58	95	49	60	0.32	95	31	60	0.21	95	17	60	0.11	95	56 (B5 - B14)
33.4	84	45	0.42	95	42	50	0.23	95	27	50	0.15	95	15	50	0.08	95	
38.0	74	45	0.36	95	37	50	0.20	95	24	50	0.13	95	13	50	0.07	95	56 (B5 - B14)
45.1	62	45	0.31	95	31	50	0.17	95	20	50	0.11	95	11	50	0.06	95	

AR 35/3 3.3

ir	n ₁ = 2800 min ⁻¹				n ₁ = 1400 min ⁻¹				n ₁ = 900 min ⁻¹				n ₁ = 500 min ⁻¹				IEC
	n ₂	T _{2M}	P	RD	n ₂	T _{2M}	P	RD	n ₂	T _{2M}	P	RD	n ₂	T _{2M}	P	RD	
	min ⁻¹	Nm	kW	%	min ⁻¹	Nm	kW	%	min ⁻¹	Nm	kW	%	min ⁻¹	Nm	kW	%	
43.9	64	54	0.39	93	31.9	60	0.22	93	20.5	60	0.14	93	11.4	60	0.08	93	63 (B5 - B14)
50.6	55	54	0.34	93	27.7	60	0.19	93	17.8	60	0.12	93	9.9	60	0.07	93	
59.1	47	54	0.29	93	23.7	60	0.16	93	15.2	60	0.10	93	8.5	60	0.06	93	56 (B5 - B14)
68.1	41	54	0.25	93	20.5	60	0.14	93	13.2	60	0.09	93	7.3	60	0.05	93	
78.6	36	60	0.24	93	17.8	60	0.12	93	11.4	60	0.08	93	6.4	60	0.04	93	56 (B5 - B14)
92.4	30	60	0.20	93	15.1	60	0.10	93	9.7	60	0.07	93	5.4	60	0.04	93	
109.1	26	60	0.17	93	12.8	60	0.09	93	8.2	60	0.06	93	4.6	60	0.03	93	56 (B5 - B14)
124.3	23	60	0.15	93	11.3	60	0.08	93	7.2	60	0.05	93	4.0	60	0.03	93	
147.7	19	60	0.13	93	9.5	60	0.06	93	6.1	60	0.04	93	3.4	60	0.02	93	56 (B5 - B14)
164.7	17	50	0.10	93	8.5	50	0.05	93	5.5	50	0.03	93	3.0	50	0.02	93	
195.6	14	50	0.08	93	7.2	50	0.04	93	4.6	50	0.03	93	2.6	50	0.01	93	

Pt _N [kW]	Tous les rapports / Todas las relaciones / Todas as relações	
	32/1	3.0
	35/2	4.5
	35/3	3.5



1.6 Performances réducteurs AR

1.6 Prestaciones reductores AR

1.6 Desempenhos redutores AR

AR 40/1



3.1

ir	$n_1 = 2800 \text{ min}^{-1}$				$n_1 = 1400 \text{ min}^{-1}$				$n_1 = 900 \text{ min}^{-1}$				$n_1 = 500 \text{ min}^{-1}$				IEC
	n_2	T_{2M}	P	RD	n_2	T_{2M}	P	RD	n_2	T_{2M}	P	RD	n_2	T_{2M}	P	RD	
	min^{-1}	Nm	kW	%	min^{-1}	Nm	kW	%	min^{-1}	Nm	kW	%	min^{-1}	Nm	kW	%	
1.2	2400	30	7.8	97	1200	30	3.9	97	771	30	2.5	97	429	30	1.4	97	100-112 (B5 - B14)
1.5	1847	35	7.0	97	923	35	3.5	97	594	35	2.2	97	330	35	1.2	97	
1.7	1655	40	7.1	97	827	40	3.6	97	532	40	2.3	97	295	40	1.3	97	
2.0	1430	45	6.9	97	715	45	3.5	97	460	45	2.2	97	255	45	1.2	97	
2.2	1257	50	6.8	97	629	50	3.4	97	404	50	2.2	97	224	50	1.2	97	
2.6	1098	50	5.9	97	549	50	3.0	97	353	50	1.9	97	196	50	1.1	97	
3.2	881	50	4.8	97	441	50	2.4	97	283	50	1.5	97	157	50	0.8	97	
3.7	750	50	4.0	97	375	50	2.0	97	241	50	1.3	97	134	50	0.7	97	
4.9	569	45	2.8	97	285	45	1.4	97	183	45	0.9	97	102	50	0.5	97	
5.7	494	40	2.1	97	247	40	1.1	97	159	42	0.7	97	88	45	0.4	97	
7.0	400	38	1.6	97	200	38	0.8	97	129	39	0.5	97	71	43	0.3	97	

AR 41/2



3.1

7.5	372	72	3.0	95	186	80	1.6	95	120	87	1.1	95	66	87	0.64	95	90 (B5 - B14)
8.5	328	77	2.8	95	164	85	1.5	95	105	93	1.1	95	59	93	0.60	95	
10.5	268	81	2.4	95	134	90	1.3	95	86	98	0.93	95	48	98	0.52	95	
12.1	232	86	2.2	95	116	95	1.2	95	74	103	0.85	95	41	103	0.47	95	
13.0	215	92	2.2	95	107	102	1.2	95	69	111	0.85	95	38	111	0.47	95	
15.3	183	95	1.9	95	91	105	1.1	95	59	114	0.74	95	33	114	0.41	95	
18.3	153	95	1.6	95	76	105	0.88	95	49	114	0.62	95	27	114	0.34	95	
20.2	139	95	1.4	95	69	105	0.80	95	45	114	0.56	95	25	114	0.31	95	
23.9	117	95	1.2	95	59	105	0.68	95	38	114	0.47	95	21	114	0.26	95	
28.6	98	95	1.0	95	49	105	0.57	95	31	114	0.40	95	17	114	0.22	95	
37.2	75	95	0.78	95	38	105	0.44	95	24	114	0.30	95	13	114	0.17	95	
49.6	56	95	0.59	95	28	105	0.33	95	18	114	0.23	95	10	114	0.13	95	

AR 41/3



3.5

54.4	52	99	0.57	93	26	110	0.32	93	17	120	0.22	93	9,2	120	0.12	93	71 (B5-B14) 63 (B5-B14)
61.3	46	99	0.51	93	23	110	0.28	93	15	120	0.20	93	8,2	120	0.11	93	
70.8	40	99	0.44	93	20	110	0.24	93	13	120	0.17	93	7,1	120	0.10	93	
82.5	34	99	0.38	93	17	110	0.21	93	11	120	0.15	93	6,1	120	0.08	93	
91.0	31	99	0.34	93	15	110	0.19	93	10	120	0.13	93	5,5	120	0.07	93	
107.4	26	99	0.29	93	13	110	0.16	93	8,4	120	0.11	93	4,7	120	0.06	93	
118.4	24	99	0.26	93	12	110	0.15	93	7,6	120	0.10	93	4,2	120	0.06	93	
128.6	22	99	0.24	93	11	110	0.13	93	7,0	120	0.09	93	3,9	120	0.05	93	
140.0	20	99	0.22	93	10	110	0.12	93	6,4	120	0.09	93	3,6	120	0.05	93	
167.4	17	99	0.19	93	8,4	110	0.10	93	5,4	120	0.07	93	3,0	120	0.04	93	
223.2	13	99	0.14	93	6,3	110	0.08	93	4,0	120	0.05	93	2,2	120	0.03	93	

P_{tN} [kW]	Tous les rapports / Todas las relaciones / Todas as relações	
	40/1	5.5
	41/2	4.5
	41/3	3.0

N.B. Pour les réducteurs caractérisés par le double bord dans la colonne des puissances, il est nécessaire de vérifier l'échange thermique du réducteur (comme au paragraphe 1.5-A). Pour toute autre information, contacter le Service Technique STM.

Nota: Para los reductores que se evidencian por el doble borde en la columna de las potencias es necesario verificar el intercambio térmico del reductor (como en el párr. 1.5-A). Para mayores informaciones, contactar la oficina técnica STM.

OBS. Para redutores marcados com duplo contorno na coluna das potências é necessário controlar a sua troca térmica (cf. Par. 1.5-A). Para maiores informações contacte o depto. Técnico STM.



1.6 Performances réducteurs AR

1.6 Prestaciones reductores AR

1.6 Desempenhos redutores AR

AR 45/2



4.1

ir	$n_1 = 2800 \text{ min}^{-1}$				$n_1 = 1400 \text{ min}^{-1}$				$n_1 = 900 \text{ min}^{-1}$				$n_1 = 500 \text{ min}^{-1}$				IEC
	n2	T2M	P	RD	n2	T2M	P	RD	n2	T2M	P	RD	n2	T2M	P	RD	
	min-1	Nm	kW	%	min-1	Nm	kW	%	min-1	Nm	kW	%	min-1	Nm	kW	%	
5.8	486	104	5.5	95	243	115	3.1	95	156	125	2.2	95	87	125	1.2	95	100 (B5 - B14)
6.4	435	108	5.2	95	218	120	2.9	95	140	131	2.0	95	78	131	1.1	95	
7.4	376	117	4.9	95	188	130	2.7	95	121	142	1.9	95	67	142	1.0	95	
8.5	331	126	4.6	95	165	140	2.6	95	106	152	1.8	95	59	152	0.99	95	
9.7	289	135	4.3	95	144	150	2.4	95	93	163	1.7	95	52	163	0.93	95	
12.1	232	144	3.7	95	116	160	2.0	95	75	174	1.4	95	41	174	0.80	95	
14.2	197	153	3.3	95	99	170	1.8	95	63	185	1.3	95	35	185	0.72	95	
16.9	165	144	2.6	95	83	160	1.5	95	53	174	1.0	95	30	174	0.57	95	
18.7	150	158	2.6	95	75	175	1.4	95	48	191	1.0	95	27	191	0.56	95	
21.5	130	162	2.3	95	65	180	1.3	95	42	196	0.90	95	23	196	0.50	95	
26.6	105	144	1.7	95	53	160	0.90	95	34	174	0.65	95	19	174	0.36	95	
30.2	93	144	1.5	95	46	160	0.82	95	30	174	0.57	95	17	174	0.32	95	
37.3	75	153	1.3	95	38	170	0.70	95	24	185	0.49	95	13	185	0.27	95	
45.9	61	153	1.0	95	31	170	0.57	95	20	185	0.40	95	11	185	0.22	95	

AR 45/3



4.6

ir	$n_1 = 2800 \text{ min}^{-1}$				$n_1 = 1400 \text{ min}^{-1}$				$n_1 = 900 \text{ min}^{-1}$				$n_1 = 500 \text{ min}^{-1}$				IEC
	n2	T2M	P	RD	n2	T2M	P	RD	n2	T2M	P	RD	n2	T2M	P	RD	
41.4	68	180	1.4	93	34	200	0.76	93	22	218	0.53	93	12	218	0.30	93	80 (B5-B14) 71 (B5-B14)
44.6	63	162	1.1	93	31	180	0.64	93	20	196	0.45	93	11	196	0.25	93	
51.6	54	180	1.1	93	27	200	0.61	93	17	218	0.43	93	10	218	0.24	93	
60.6	46	180	0.9	93	23	200	0.52	93	15	218	0.36	93	8.2	218	0.20	93	
72.4	39	162	0.71	93	19	180	0.39	93	12	196	0.27	93	6.9	196	0.15	93	
79.8	35	180	0.71	93	18	200	0.39	93	11	218	0.28	93	6.3	218	0.15	93	
92.0	30	180	0.62	93	15	200	0.34	93	10	218	0.24	93	5.4	218	0.13	93	
113.7	25	162	0.45	93	12	180	0.25	93	7.9	196	0.17	93	4.4	196	0.10	93	
129.1	22	162	0.40	93	11	180	0.22	93	7.0	196	0.15	93	3.9	196	0.09	93	
159.5	18	162	0.32	93	8.8	180	0.18	93	5.6	196	0.12	93	3.1	196	0.07	93	
196.0	14	162	0.26	93	7.1	180	0.14	93	4.6	196	0.10	93	2.6	196	0.06	93	

Pt _N [kW]	Tous les rapports / Todas las relaciones / Todas as relações	
	45/2	5.0
	45/3	4.1

N.B. Pour les réducteurs caractérisés par le double bord dans la colonne des puissances, il est nécessaire de vérifier l'échange thermique du réducteur (comme au paragraphe 1.5-A). Pour toute autre information, contacter le Service Technique STM.

Nota: Para los reductores que se evidencian por el doble borde en la columna de las potencias es necesario verificar el intercambio térmico del reductor (como en el párr. 1.5-A). Para mayores informaciones, contactar la oficina técnica STM.

OBS. Para redutores marcados com duplo contorno na coluna das potências é necessário controlar a sua troca térmica (cf. Par. 1.5-A). Para maiores informações contacte o depto. Técnico STM.



1.6 Performances réducteurs AR

1.6 Prestaciones reductores AR

1.6 Desempenhos redutores AR

AR 50/1



5.2

ir	n ₁ = 2800 min ⁻¹				n ₁ = 1400 min ⁻¹				n ₁ = 900 min ⁻¹				n ₁ = 500 min ⁻¹				IEC
	n ₂	T _{2M}	P	RD	n ₂	T _{2M}	P	RD	n ₂	T _{2M}	P	RD	n ₂	T _{2M}	P	RD	
	min ⁻¹	Nm	kW	%	min ⁻¹	Nm	kW	%	min ⁻¹	Nm	kW	%	min ⁻¹	Nm	kW	%	
1.3	2240	55	13.3	97	1120	55	6.6	97	720	55	4.3	97	400	55	2.4	97	112 (B5 - B14)
1.5	1830	63	12.4	97	915	63	6.2	97	588	63	4.0	97	327	63	2.2	97	
1.8	1547	80	13.4	97	773	80	6.7	97	497	80	4.3	97	276	80	2.4	97	100 (B5 - B14)
2.0	1373	80	11.8	97	686	80	5.9	97	441	80	3.8	97	245	80	2.1	97	
2.5	1129	80	9.8	97	565	80	4.9	97	363	80	3.1	97	202	80	1.7	97	90 (B5 - B14)
2.8	986	85	9.0	97	493	85	4.5	97	317	85	2.9	97	176	85	1.6	97	
3.1	915	90	8.9	97	458	90	4.5	97	294	90	2.9	97	163	90	1.6	97	80 (B5 - B14)
3.3	851	90	8.3	97	426	90	4.1	97	274	90	2.7	97	152	90	1.5	97	
3.6	787	90	7.6	97	393	90	3.8	97	253	90	2.5	97	140	90	1.4	97	71 (B5)
3.9	724	90	7.0	97	362	90	3.5	97	233	90	2.3	97	129	90	1.3	97	
5.1	551	72	4.3	97	276	75	2.2	97	177	75	1.4	97	98	80	0.8	97	63 (B5)
5.8	480	63	3.3	97	240	65	1.7	97	154	65	1.1	97	86	73	0.7	97	
6.6	426	60	2.8	97	213	60	1.4	97	137	60	0.9	97	76	70	0.6	97	

AR 50/2



13

2.6	1077	99	11.8	95	538	118	7.0	95	346	132	5.0	95	192	182	3.9	95	112 (B5 - B14)
2.9	952	104	10.9	95	476	124	6.5	95	306	138	4.7	95	170	190	3.6	95	
4.4	636	112	7.9	95	318	133	4.7	95	205	148	3.3	95	114	200	2.5	95	100 (B5 - B14)
5.1	546	118	7.1	95	273	140	4.2	95	175	157	3.0	95	97	200	2.1	95	
6.3	448	124	6.1	95	224	147	3.6	95	144	164	2.6	95	80	200	1.8	95	90 (B5 - B14)
7.4	379	128	5.4	95	190	153	3.2	95	122	171	2.3	95	68	200	1.5	95	
8.3	336	133	4.9	95	168	158	2.9	95	108	176	2.1	95	60	20	1.3	95	80 (B5 - B14)
9.2	304	137	4.6	95	152	163	2.7	95	98	182	2.0	95	54	200	1.2	95	
10.4	269	144	4.3	95	134	171	2.5	95	86	191	1.8	95	48	200	1.1	95	71 (B5)
12.5	224	147	3.6	95	112	175	2.2	95	72	195	1.6	95	40	210	0.93	95	
14.6	192	153	3.2	95	96	182	1.9	95	62	203	1.4	95	34	210	0.80	95	63 (B5)
16.8	167	158	2.9	95	83	188	1.7	95	54	210	1.2	95	30	210	0.69	95	
18.2	154	156	2.6	95	77	184	1.6	95	50	200	1.1	95	28	200	0.61	95	63 (B5)
20.8	135	159	2.4	95	67	189	1.4	95	43	200	0.96	95	24	200	0.63	95	
23.8	118	171	2.2	95	59	203	1.3	95	38	210	0.87	95	21	210	0.49	95	
25.9	108	168	2.0	95	54	200	1.2	95	35	200	0.77	95	19	200	0.43	95	
29.8	94	168	1.7	95	47	200	1.0	95	30	200	0.67	95	17	200	0.37	95	

AR 50/3



13

28.5	98	182	2.0	93	49	216	1.2	93	32	216	0.77	93	18	216	0.43	93	90 (B5 - B14)
32.4	86	188	1.8	93	43	216	1.1	93	28	216	0.68	93	15	216	0.38	93	
35.6	79	186	1.6	93	39	208	0.92	93	25	208	0.59	93	14	208	0.33	93	80 (B5 - B14)
40.5	69	191	1.5	93	35	208	0.81	93	22	208	0.52	93	12	208	0.29	93	
46.2	61	205	1.4	93	30	216	0.74	93	19	216	0.47	93	11	216	0.26	93	71 (B5)
50.8	55	210	1.3	93	28	216	0.67	93	18	216	0.43	93	9.8	216	0.24	93	
54.3	52	216	1.3	93	26	216	0.63	93	17	216	0.40	93	9.2	216	0.22	93	63 (B5)
65.9	42	208	1.0	93	21	208	0.50	93	14	208	0.32	93	7.6	208	0.18	93	
71.5	39	216	0.95	93	20	216	0.48	93	13	216	0.31	93	7.0	216	0.17	93	
77.5	36	216	0.88	93	18	216	0.44	93	12	216	0.28	93	6.5	216	0.16	93	
89.3	31	216	0.76	93	16	216	0.38	93	10	216	0.25	93	5.6	216	0.14	93	
102.1	27	208	0.64	93	14	208	0.32	93	8.8	208	0.21	93	4.9	208	0.11	93	
117.6	24	216	0.58	93	12	216	0.29	93	7.7	216	0.19	93	4.3	216	0.10	93	
127.5	22	216	0.53	93	11	216	0.27	93	7.1	216	0.17	93	3.9	216	0.10	93	
146.9	19	208	0.45	93	9.5	208	0.22	93	6.1	208	0.14	93	3.4	208	0.08	93	
181.5	15	205	0.35	93	7.7	205	0.18	93	4.9	205	0.11	93	2.7	205	0.06	93	

Pt _N [kW]	Tous les rapports / Todas las relaciones / Todas as relações	
	50/1	6.5
	50/2	6.3
50/3	4.5	

N.B. Pour les réducteurs caractérisés par le double bord dans la colonne des puissances, il est nécessaire de vérifier l'échange thermique du réducteur (comme au paragraphe 1.5-A). Pour toute autre information, contacter le Service Technique STM.

Nota: Para los reductores que se evidencian por el doble borde en la columna de las potencias es necesario verificar el intercambio térmico del reductor (como en el párr. 1.5-A). Para mayores informaciones, contactar la oficina técnica STM.

OBS. Para redutores marcados com duplo contorno na coluna das potências é necessário controlar a sua troca térmica (cf. Par. 1.5-A). Para maiores informações contacte o depto. Técnico STM.



AR 55/2



17

ir	$n_1 = 2800 \text{ min}^{-1}$				$n_1 = 1400 \text{ min}^{-1}$				$n_1 = 900 \text{ min}^{-1}$				$n_1 = 500 \text{ min}^{-1}$				IEC
	n_2	T_{2M}	P	RD	n_2	T_{2M}	P	RD	n_2	T_{2M}	P	RD	n_2	T_{2M}	P	RD	
	min^{-1}	Nm	kW	%	min^{-1}	Nm	kW	%	min^{-1}	Nm	kW	%	min^{-1}	Nm	kW	%	
4.3	651.6	180.0	12.9	95.0	325.8	200.0	7.2	95.0	209.5	217.8	5.0	95.0	116.4	217.8	2.8	95.0	112 (B5 - B14)
5.3	531.9	189.0	11.1	95.0	266.0	210.0	6.2	95.0	171.0	228.7	4.3	95.0	95.0	228.7	2.4	95.0	
6.2	450.6	207.0	10.3	95.0	225.3	230.0	5.7	95.0	144.8	250.4	4.0	95.0	80.5	250.4	2.2	95.0	
6.8	410.7	198.0	9.0	95.0	205.3	220.0	5.0	95.0	132.0	239.6	3.5	95.0	73.3	239.6	1.9	95.0	
7.0	399.0	216.0	9.5	95.0	199.5	240.0	5.3	95.0	128.2	261.3	3.7	95.0	71.2	261.3	2.1	95.0	
8.4	335.2	207.0	7.6	95.0	167.6	230.0	4.2	95.0	107.8	250.4	3.0	95.0	59.9	250.4	1.7	95.0	
9.9	284.0	234.0	7.3	95.0	142.0	260.0	4.1	95.0	91.3	283.1	2.8	95.0	50.7	283.1	1.6	95.0	
11.1	251.4	234.0	6.5	95.0	125.7	260.0	3.6	95.0	80.8	283.1	2.5	95.0	44.9	283.1	1.4	95.0	
12.2	228.6	252.0	6.4	95.0	114.3	280.0	3.5	95.0	73.5	304.9	2.5	95.0	40.8	304.9	1.4	95.0	
13.5	207.3	261.0	6.0	95.0	103.7	290.0	3.3	95.0	66.6	315.8	2.3	95.0	37.0	315.8	1.3	95.0	
15.5	180.6	252.0	5.0	95.0	90.3	280.0	2.8	95.0	58.1	304.9	2.0	95.0	32.3	304.9	1.1	95.0	
16.7	168.0	261.0	4.8	95.0	84.0	290.0	2.7	95.0	54.0	315.8	1.9	95.0	30.0	315.8	1.0	95.0	
18.0	155.8	261.0	4.5	95.0	77.9	290.0	2.5	95.0	50.1	315.8	1.7	95.0	27.8	315.8	1.0	95.0	
19.4	144.1	270.0	4.3	95.0	72.0	300.0	2.4	95.0	46.3	326.7	1.7	95.0	25.7	326.7	0.93	95.0	
21.1	132.8	270.0	4.0	95.0	66.4	300.0	2.2	95.0	42.7	326.7	1.5	95.0	23.7	326.7	0.85	95.0	
22.6	123.7	207.0	2.8	95.0	61.9	230.0	1.6	95.0	39.8	250.4	1.1	95.0	22.1	250.4	0.61	95.0	
27.7	101.0	270.0	3.0	95.0	50.5	300.0	1.7	95.0	32.5	326.7	1.2	95.0	18.0	326.7	0.65	95.0	
31.8	88.0	270.0	2.6	95.0	44.0	300.0	1.5	95.0	28.3	326.7	1.0	95.0	15.7	326.7	0.57	95.0	
35.9	78.0	270.0	2.3	95.0	39.0	300.0	1.3	95.0	25.1	326.7	0.90	95.0	13.9	326.7	0.50	95.0	
40.2	69.7	252.0	1.9	95.0	34.8	280.0	1.1	95.0	22.4	304.9	0.75	95.0	12.4	304.9	0.42	95.0	
45.4	61.7	252.0	1.7	95.0	30.9	280.0	1.0	95.0	19.8	304.9	0.67	95.0	11.0	304.9	0.37	95.0	

AR 55/3



17

32.3	86.6	270.0	2.6	93.0	43.3	300.0	1.5	93.0	27.8	326.7	1.0	93.0	15.5	326.7	0.57	93.0	90 (B5 - B14)
38.1	73.6	270.0	2.2	93.0	36.8	300.0	1.2	93.0	23.7	326.7	0.87	93.0	13.1	326.7	0.48	93.0	
42.0	66.6	270.0	2.0	93.0	33.3	300.0	1.1	93.0	21.4	326.7	0.79	93.0	11.9	326.7	0.44	93.0	
46.9	59.7	270.0	1.8	93.0	29.8	300.0	1.0	93.0	19.2	326.7	0.71	93.0	10.7	326.7	0.39	93.0	
49.6	56.5	270.0	1.7	93.0	28.3	300.0	0.95	93.0	18.2	326.7	0.67	93.0	10.1	326.7	0.37	93.0	
54.3	51.6	270.0	1.6	93.0	25.8	300.0	0.87	93.0	16.6	326.7	0.61	93.0	9.2	326.7	0.34	93.0	
61.8	45.3	270.0	1.4	93.0	22.7	300.0	0.77	93.0	14.6	326.7	0.54	93.0	8.1	326.7	0.30	93.0	
65.2	42.9	270.0	1.3	93.0	21.5	300.0	0.72	93.0	13.8	326.7	0.51	93.0	7.7	326.7	0.28	93.0	
72.5	38.6	270.0	1.2	93.0	19.3	300.0	0.65	93.0	12.4	326.7	0.46	93.0	6.9	326.7	0.25	93.0	
78.0	35.9	252.0	1.0	93.0	17.9	280.0	0.57	93.0	11.5	304.9	0.40	93.0	6.4	304.9	0.24	93.0	
88.1	31.8	270.0	0.97	93.0	15.9	300.0	0.54	93.0	10.2	326.7	0.38	93.0	5.7	326.7	0.21	93.0	
95.5	29.3	270.0	0.89	93.0	14.7	300.0	0.49	93.0	9.4	326.7	0.35	93.0	5.2	326.7	0.19	93.0	
103.5	27.0	270.0	0.82	93.0	13.5	300.0	0.46	93.0	8.7	326.7	0.32	93.0	4.8	326.7	0.18	93.0	
110.1	25.4	270.0	0.77	93.0	12.7	300.0	0.43	93.0	8.2	326.7	0.30	93.0	4.5	326.7	0.17	93.0	
122.3	22.9	270.0	0.70	93.0	11.4	300.0	0.39	93.0	7.4	326.7	0.27	93.0	4.1	326.7	0.15	93.0	
136.3	20.5	270.0	0.62	93.0	10.3	300.0	0.35	93.0	6.6	326.7	0.24	93.0	3.7	326.7	0.13	93.0	
157.1	17.8	270.0	0.54	93.0	8.9	300.0	0.30	93.0	5.7	326.7	0.21	93.0	3.2	326.7	0.12	93.0	
167.1	16.8	270.0	0.51	93.0	8.4	300.0	0.28	93.0	5.4	326.7	0.20	93.0	3.0	326.7	0.11	93.0	
194.1	14.4	270.0	0.44	93.0	7.2	300.0	0.24	93.0	4.6	326.7	0.17	93.0	2.6	326.7	0.09	93.0	
211.1	13.3	252.0	0.38	93.0	6.6	280.0	0.21	93.0	4.3	304.9	0.15	93.0	2.4	304.9	0.09	93.0	
238.5	11.7	270.0	0.36	93.0	5.9	300.0	0.20	93.0	3.8	326.7	0.14	93.0	2.1	326.7	0.08	93.0	
301.2	9.3	252.0	0.26	93.0	4.6	280.0	0.15	93.0	3.0	304.9	0.10	93.0	1.7	304.9	0.06	93.0	

90
(B5 - B14)
80
(B5 - B14)
71 (B5)
63 (B5)

P_{tN} [kW]	Tous les rapports / Todas las relaciones / Todas as relações	
	55/2	7.0
	55/3	5.0

N.B. Pour les réducteurs caractérisés par le double bord dans la colonne des puissances, il est nécessaire de vérifier l'échange thermique du réducteur (comme au paragraphe 1.5-A). Pour toute autre information, contacter le Service Technique STM.

Nota: Para los reductores que se evidencian por el doble borde en la columna de las potencias es necesario verificar el intercambio térmico del reductor (como en el párr. 1.5-A). Para mayores informaciones, contactar la oficina técnica STM.

OBS. Para redutores marcados com duplo contorno na coluna das potências é necessário controlar a sua troca térmica (cf. Par. 1.5-A). Para maiores informações contacte o depto. Técnico STM.



1.6 Performances réducteurs AR

1.6 Prestaciones reductores AR

1.6 Desempenhos redutores AR

AR 60/1



16

ir	n ₁ = 2800 min ⁻¹				n ₁ = 1400 min ⁻¹				n ₁ = 900 min ⁻¹				n ₁ = 500 min ⁻¹				IEC
	n ₂	T _{2M}	P	RD	n ₂	T _{2M}	P	RD	n ₂	T _{2M}	P	RD	n ₂	T _{2M}	P	RD	
	min ⁻¹	Nm	kW	%	min ⁻¹	Nm	kW	%	min ⁻¹	Nm	kW	%	min ⁻¹	Nm	kW	%	
1.3	2133	130	29.9	97	1067	130	15.0	97	686	130	9.6	97	381	130	5.3	97	132 (B5 - B14)
1.6	1704	140	25.8	97	852	140	12.9	97	548	140	8.3	97	304	140	4.6	97	
1.8	1517	145	23.7	97	758	145	11.9	97	488	145	7.6	97	271	145	4.2	97	112 (B5 - B14)
2.1	1344	160	23.2	97	672	160	11.6	97	432	160	7.5	97	240	160	4.1	97	
2.4	1185	170	21.7	97	592	170	10.9	97	381	170	7.0	97	212	170	3.9	97	100 (B5 - B14)
2.7	1037	170	19.0	97	519	170	9.5	97	333	170	6.1	97	185	170	3.4	97	
2.9	967	170	17.8	97	484	170	8.9	97	311	170	5.7	97	173	170	3.2	97	90(B5 - B14)
3.4	835	170	15.3	97	418	170	7.7	97	268	170	4.9	97	149	170	2.7	97	
3.6	772	170	14.2	97	386	170	7.1	97	248	170	4.6	97	138	170	2.5	97	80 (B5 - B14)
4.7	597	170	11.0	97	298	170	5.5	97	192	170	3.5	97	107	170	2.0	97	
5.2	542	158	9.2	97	271	164	4.8	97	174	164	3.1	97	97	164	1.7	97	71 (B5)
5.9	473	142	7.2	97	236	146	3.7	97	152	155	2.5	97	84	160	1.5	97	
6.8	410	125	5.5	97	205	125	2.8	97	132	132	1.9	97	73	142	1.1	97	

AR 60/2



20

2.6	1061	213	25	95	530	253	14.8	95	341	283	10.6	95	189	389	8.1	95	132 (B5 - B14)
3.7	763	223	18.8	95	381	265	11.1	95	245	296	8.0	95	136	407	6.1	95	
4.3	657	239	17.3	95	329	285	10.3	95	211	318	7.4	95	117	410	5.3	95	112 (B5 - B14)
4.6	609	253	17.0	95	304	301	10.1	95	196	336	7.2	95	109	410	4.9	95	
6.6	427	265	12.5	95	213	315	7.4	95	137	352	5.3	95	76	410	3.4	95	100 (B5 - B14)
7.5	372	275	11.3	95	186	327	6.7	95	120	366	4.8	95	66	410	3.0	95	
7.9	355	285	11.1	95	177	338	6.6	95	114	378	4.8	95	63	410	2.9	95	90 (B5)
8.9	315	293	10.2	95	157	349	6.1	95	101	389	4.3	95	56	410	2.5	95	
10.1	279	301	9.2	95	139	359	5.5	95	90	400	3.9	95	50	410	2.2	95	80 (B5)
11.3	247	308	8.4	95	123	367	5.0	95	79	409	3.6	95	44	410	2.0	95	
12.4	226	315	7.9	95	113	375	4.7	95	73	418	3.4	95	40	450	2.0	95	71 (B5)
14.3	195	327	7.0	95	98	389	4.2	95	63	435	3.0	95	35	450	1.7	95	
15.5	181	338	6.7	95	90	402	4.0	95	58	449	2.9	95	32	450	1.6	95	80 (B5)
18.3	153	318	5.4	95	77	378	3.2	95	49	410	2.2	95	27	410	1.2	95	
19.7	142	326	5.1	95	71	388	3.0	95	46	410	2.1	95	25	410	1.1	95	71 (B5)
22.1	127	367	5.1	95	63	436	3.0	95	41	450	2.0	95	23	450	1.1	95	
25.3	111	378	4.6	95	55	450	2.7	95	36	450	1.8	95	20	450	0.98	95	71 (B5)
28.1	100	345	3.8	95	50	410	2.2	95	32	410	1.4	95	18	410	0.80	95	
32.3	87	345	3.3	95	43	410	2.0	95	28	410	1.3	95	16	410	0.70	95	

AR 60/3



20

28.0	100	387	4.4	93	50	460	2.6	93	32	460	1.7	93	18	460	0.92	93	100 (B5 - B14)
31.6	89	400	4.0	93	44	460	2.3	93	28	460	1.5	93	16	460	0.82	93	
35.7	78	376	3.3	93	39	420	1.9	93	25	420	1.2	93	14	420	0.66	93	90 (B5 - B14)
40.3	69	386	3.0	93	35	420	1.6	93	22	420	1.1	93	12	420	0.59	93	
45.1	62	436	3.0	93	31	460	1.6	93	20	460	1.0	93	11	460	0.57	93	80 (B5 - B14)
51.0	55	447	2.8	93	27	460	1.4	93	18	460	0.91	93	9.8	460	0.51	93	
55.2	51	460	2.6	93	25	460	1.3	93	16	460	0.84	93	9.1	460	0.47	93	71 (B5)
60.3	46	420	2.2	93	23	420	1.1	93	15	420	0.71	93	8.3	420	0.39	93	
72.7	39	460	2.0	93	19	460	1.0	93	12	460	0.64	93	6.9	460	0.36	93	80 (B5 - B14)
78.6	36	460	1.8	93	18	460	0.92	93	11	460	0.59	93	6.4	460	0.33	93	
90.4	31	460	1.6	93	15	460	0.80	93	10	460	0.52	93	5.5	460	0.29	93	71 (B5)
100.2	28	420	1.3	93	14	420	0.66	93	9.0	420	0.42	93	5.0	420	0.24	93	
112.2	25	460	1.3	93	12	460	0.65	93	8.0	460	0.42	93	4.5	460	0.23	93	71 (B5)
128.8	22	460	1.1	93	11	460	0.56	93	7.0	460	0.36	93	3.9	460	0.20	93	
143.0	20	420	0.93	93	9.8	420	0.46	93	6.3	420	0.30	93	3.5	420	0.17	93	71 (B5)
164.1	17	420	0.81	93	8.5	420	0.40	93	5.5	420	0.26	93	3.0	420	0.14	93	
185.2	15	420	0.71	93	7.5	420	0.36	93	4.8	420	0.23	93	2.7	420	0.13	93	

Pt _N [kW]	Tous les rapports / Todas las relaciones / Todas as relações	
	60/1	9.0
	60/2	9.6
60/3	6.9	



AR 70/2



30

ir	$n_1 = 2800 \text{ min}^{-1}$				$n_1 = 1400 \text{ min}^{-1}$				$n_1 = 900 \text{ min}^{-1}$				$n_1 = 500 \text{ min}^{-1}$				IEC
	n_2	T_{2M}	P	RD	n_2	T_{2M}	P	RD	n_2	T_{2M}	P	RD	n_2	T_{2M}	P	RD	
	min^{-1}	Nm	kW	%	min^{-1}	Nm	kW	%	min^{-1}	Nm	kW	%	min^{-1}	Nm	kW	%	
4.5	619.4	324.0	22.1	95	309.7	360.0	12.3	95	199.1	392.0	8.6	95	110.6	392.0	4.8	95	132 (B5 - B14)
5.7	494.8	342.0	18.7	95	247.4	380.0	10.4	95	159.0	413.8	7.3	95	88.4	413.8	4.0	95	
6.4	440.3	360.0	17.5	95	220.2	400.0	9.7	95	141.5	435.6	6.8	95	78.6	435.6	3.8	95	
7.2	390.2	378.0	16.3	95	195.1	420.0	9.0	95	125.4	457.3	6.3	95	69.7	457.3	3.5	95	
8.1	343.9	405.0	15.4	95	172.0	450.0	8.5	95	110.5	490.0	6.0	95	61.4	490.0	3.3	95	
9.3	301.1	423.0	14.0	95	150.5	470.0	7.8	95	96.8	511.8	5.5	95	53.8	511.8	3.0	95	
10.0	280.8	432.0	13.4	95	140.4	480.0	7.4	95	90.3	522.7	5.2	95	50.1	522.7	2.9	95	
11.8	237.2	468.0	12.2	95	118.6	520.0	6.8	95	76.2	566.2	4.8	95	42.4	566.2	2.6	95	
12.5	224.2	459.0	11.3	95	112.1	510.0	6.3	95	72.1	555.3	4.4	95	40.0	555.3	2.5	95	
13.4	209.0	486.0	11.2	95	104.5	540.0	6.2	95	67.2	588.0	4.4	95	37.3	588.0	2.4	95	
15.3	183.0	477.0	9.6	95	91.5	530.0	5.3	95	58.8	577.1	3.7	95	32.7	577.1	2.1	95	
17.8	157.3	495.0	8.6	95	78.7	550.0	4.8	95	50.6	598.9	3.3	95	28.1	598.9	1.9	95	
20.5	136.3	495.0	7.4	95	68.2	550.0	4.1	95	43.8	598.9	2.9	95	24.3	598.9	1.6	95	
23.5	119.0	387.0	5.1	95	59.5	430.0	2.8	95	38.2	468.2	2.0	95	21.2	468.2	1.1	95	
26.6	105.3	504.0	5.8	95	52.7	560.0	3.2	95	33.8	609.8	2.3	95	18.8	609.8	1.3	95	
29.3	95.6	513.0	5.4	95	47.8	570.0	3.0	95	30.7	620.7	2.1	95	17.1	620.7	1.2	95	
33.6	83.4	513.0	4.7	95	41.7	570.0	2.6	95	26.8	620.7	1.8	95	14.9	620.7	1.0	95	
38.7	72.3	531.0	4.2	95	36.2	590.0	2.4	95	23.2	642.4	1.6	95	12.9	642.4	0.91	95	
45.4	61.7	396.0	2.7	95	30.8	440.0	1.5	95	19.8	479.1	1.0	95	11.0	479.1	0.58	95	
52.4	53.4	396.0	2.3	95	26.7	440.0	1.3	95	17.2	479.1	0.91	95	9.5	479.1	0.50	95	

AR 70/3



30

37.1	75.4	540.0	4.6	93	37.7	600.0	2.5	93	24.2	653.3	1.8	93	13.5	653.3	0.99	93	100 (B5 - B14)
41.9	66.8	540.0	4.1	93	33.4	600.0	2.3	93	21.5	653.3	1.6	93	11.9	653.3	0.88	93	
50.9	55.0	540.0	3.3	93	27.5	600.0	1.9	93	17.7	653.3	1.3	93	9.8	653.3	0.72	93	
52.9	52.9	540.0	3.2	93	26.5	600.0	1.8	93	17.0	653.3	1.3	93	9.4	653.3	0.69	93	
59.8	46.8	540.0	2.8	93	23.4	600.0	1.6	93	15.1	653.3	1.1	93	8.4	653.3	0.62	93	
67.7	41.4	540.0	2.5	93	20.7	600.0	1.4	93	13.3	653.3	1.0	93	7.4	653.3	0.54	93	
72.5	38.6	540.0	2.3	93	19.3	600.0	1.3	93	12.4	653.3	0.91	93	6.9	653.3	0.51	93	
83.2	33.6	540.0	2.0	93	16.8	600.0	1.1	93	10.8	653.3	0.80	93	6.0	653.3	0.44	93	
89.5	31.3	540.0	1.9	93	15.6	600.0	1.1	93	10.1	653.3	0.74	93	5.6	653.3	0.41	93	
96.4	29.0	540.0	1.8	93	14.5	600.0	1.0	93	9.3	653.3	0.69	93	5.2	653.3	0.38	93	
104.3	26.8	540.0	1.6	93	13.4	600.0	0.91	93	8.6	653.3	0.63	93	4.8	653.3	0.35	93	
113.2	24.7	540.0	1.5	93	12.4	600.0	0.84	93	8.0	653.3	0.58	93	4.4	653.3	0.32	93	
119.8	23.4	540.0	1.4	93	11.7	600.0	0.79	93	7.5	653.3	0.55	93	4.2	653.3	0.31	93	
135.2	20.7	540.0	1.3	93	10.4	600.0	0.70	93	6.7	653.3	0.49	93	3.7	653.3	0.27	93	
148.8	18.8	540.0	1.1	93	9.4	600.0	0.64	93	6.0	653.3	0.44	93	3.4	653.3	0.25	93	
170.8	16.4	540.0	1.0	93	8.2	600.0	0.55	93	5.3	653.3	0.39	93	2.9	653.3	0.22	93	
192.7	14.5	540.0	0.88	93	7.3	600.0	0.49	93	4.7	653.3	0.34	93	2.6	653.3	0.19	93	
231.1	12.1	450.0	0.61	93	6.1	500.0	0.34	93	3.9	544.4	0.24	93	2.2	544.4	0.13	93	
260.8	10.7	468.0	0.57	93	5.4	520.0	0.31	93	3.5	566.2	0.22	93	1.9	566.2	0.12	93	

P_{tN} [kW]	Tous les rapports / Todas las relaciones / Todas as relações	
	70/2	12.0
	70/3	8.6

N.B. Pour les réducteurs caractérisés par le double bord dans la colonne des puissances, il est nécessaire de vérifier l'échange thermique du réducteur (comme au paragraphe 1.5-A). Pour toute autre information, contacter le Service Technique STM.

Nota: Para los reductores que se evidencian por el doble borde en la columna de las potencias es necesario verificar el intercambio térmico del reductor (como en el párr. 1.5-A). Para mayores informaciones, contactar la oficina técnica STM.

OBS. Para redutores marcados com duplo contorno na coluna das potências é necessário controlar a sua troca térmica (cf. Par. 1.5-A). Para maiores informações contacte o depto. Técnico STM.



1.6 Performances réducteurs AR

1.6 Prestaciones reductores AR

1.6 Desempenhos redutores AR

AR 80/1

Kg 21

ir	n ₁ = 2800 min ⁻¹				n ₁ = 1400 min ⁻¹				n ₁ = 900 min ⁻¹				n ₁ = 500 min ⁻¹				IEC
	n ₂	T _{2M}	P	RD	n ₂	T _{2M}	P	RD	n ₂	T _{2M}	P	RD	n ₂	T _{2M}	P	RD	
	min ⁻¹	Nm	kW	%	min ⁻¹	Nm	kW	%	min ⁻¹	Nm	kW	%	min ⁻¹	Nm	kW	%	
1.2	2355	260	66.1	97	1177	260	33.0	97	757	260	21.2	97	420	260	11.8	97	160 (B5) 132 (B5) 112 (B5) 100 (B5) 90 (B5) 80 (B5)
1.4	2026	270	59.0	97	1013	270	29.5	97	651	270	19.0	97	362	270	10.5	97	
1.8	1532	280	46.3	97	766	280	23.2	97	492	280	14.9	97	274	280	8.3	97	
2.0	1375	305	45.3	97	687	305	22.6	97	442	305	14.5	97	245	305	8.1	97	
2.4	1179	330	42.0	97	589	330	21.0	97	379	330	13.5	97	211	330	7.5	97	
2.7	1044	330	37.2	97	522	330	18.6	97	336	330	12.0	97	186	330	6.6	97	
2.9	964	330	34.3	97	482	330	17.2	97	310	330	11.0	97	172	330	6.1	97	
3.3	844	330	30.1	97	422	330	15.0	97	271	330	9.7	97	151	330	5.4	97	
3.6	788	330	28.1	97	394	330	14.0	97	253	330	9.0	97	141	330	5.0	97	
4.8	585	330	20.8	97	293	330	10.4	97	188	330	6.7	97	104	330	3.7	97	
5.3	528	330	18.8	97	264	330	9.4	97	170	330	6.0	97	94	330	3.4	97	
5.8	480	330	17.1	97	240	330	8.5	97	154	330	5.5	97	86	330	3.1	97	
6.4	439	330	15.6	97	219	330	7.8	97	141	330	5.0	97	78	330	2.8	97	

AR 80/2

Kg 42

2.6	1081	444	53	95	541	529	32	95	347	590	23	95	193	813	17.3	95	160 (B5) 132 (B5) 112 (B5) 100 (B5) 90 (B5) 80 (B5)
3.7	759	465	39	95	379	553	23	95	244	618	16.6	95	136	851	12.7	95	
4.2	665	500	37	95	333	595	22	95	214	664	15.6	95	119	915	12.0	95	
4.5	621	529	36	95	310	629	22	95	200	702	15.4	95	111	940	11.5	95	
6.7	415	553	25	95	208	658	15.1	95	134	735	10.8	95	74	940	7.7	95	
7.4	378	575	24	95	189	684	14.3	95	122	764	10.2	95	68	940	7.0	95	
7.8	359	595	24	95	179	707	14.0	95	115	790	10.0	95	64	940	6.6	95	
8.7	322	612	22	95	161	728	12.9	95	103	813	9.3	95	57	940	6.0	95	
10.0	281	629	19.5	95	141	748	11.6	95	90	835	8.3	95	50	940	5.2	95	
11.1	252	644	17.9	95	126	766	10.7	95	81	855	7.6	95	45	940	4.7	95	
12.4	226	658	16.4	95	113	782	9.7	95	73	874	7.0	95	40	940	4.2	95	
14.2	198	684	14.9	95	99	813	8.9	95	64	908	6.4	95	35	940	3.7	95	
15.2	184	707	14.4	95	92	841	8.5	95	59	939	6.1	95	33	940	3.4	95	
18.1	155	728	12.4	95	78	866	7.4	95	50	940	5.2	95	28	940	2.9	95	
19.4	145	748	11.9	95	72	889	7.1	95	46	940	4.8	95	26	940	2.7	95	
22.7	123	766	10.4	95	62	910	6.2	95	40	940	4.1	95	22	940	2.3	95	
24.9	112	790	9.8	95	56	940	5.8	95	36	940	3.7	95	20	940	2.1	95	
28.9	97	790	8.4	95	48	940	5.0	95	31	940	3.2	95	17	940	1.8	95	
31.8	88	790	7.7	95	44	940	4.6	95	28	940	2.9	95	16	940	1.6	95	

AR 80/3

Kg 42

28.1	100	813	9.1	93	50	967	5.4	93	32	967	3.5	93	18	967	1.9	93	112 (B5) 100 (B5) 90 (B5) 80 (B5)
31.7	88	841	8.4	93	44	967	4.8	93	28	967	3.1	93	16	967	1.7	93	
35.7	78	866	7.6	93	39	967	4.3	93	25	967	2.7	93	14	967	1.5	93	
40.3	69	889	6.9	93	35	967	3.8	93	22	967	2.4	93	12	967	1.3	93	
44.0	64	916	6.6	93	32	967	3.5	93	20	967	2.2	93	11	967	1.2	93	
50.9	55	940	5.8	93	27	967	3.0	93	18	967	1.9	93	9.8	967	1.1	93	
55.1	51	967	5.5	93	25	967	2.8	93	16	967	1.8	93	9.1	967	0.99	93	
65.7	43	967	4.6	93	21	967	2.3	93	14	967	1.5	93	7.6	967	0.83	93	
76.0	37	967	4.0	93	18	967	2.0	93	12	967	1.3	93	6.6	967	0.72	93	
82.2	34	967	3.7	93	17	967	1.9	93	11	967	1.2	93	6.1	967	0.66	93	
90.0	31	967	3.4	93	16	967	1.7	93	10	967	1.1	93	5.6	967	0.61	93	
104.8	27	967	2.9	93	13	967	1.6	93	8.6	967	0.94	93	4.8	967	0.52	93	
117.2	24	967	2.6	93	12	967	1.3	93	7.7	967	0.84	93	4.3	967	0.46	93	
134.3	21	967	2.3	93	10	967	1.1	93	6.7	967	0.73	93	3.7	967	0.41	93	
149.3	19	967	2.0	93	9.4	967	1.0	93	6.0	967	0.66	93	3.3	967	0.36	93	
171.2	16	967	1.8	93	8.2	967	0.89	93	5.3	967	0.57	93	2.9	967	0.32	93	
197.5	14	967	1.5	93	7.1	967	0.77	93	4.5	967	0.50	93	2.5	967	0.27	93	

Pt _N [kW]	Tous les rapports / Todas las relaciones / Todas as relações	
	80/1	14.0
	80/2	15.0
80/3	10.7	



AR 90/2



48

ir	$n_1 = 2800 \text{ min}^{-1}$				$n_1 = 1400 \text{ min}^{-1}$				$n_1 = 900 \text{ min}^{-1}$				$n_1 = 500 \text{ min}^{-1}$				IEC
	n_2	T_{2M}	P	RD	n_2	T_{2M}	P	RD	n_2	T_{2M}	P	RD	n_2	T_{2M}	P	RD	
	min^{-1}	Nm	kW	%	min^{-1}	Nm	kW	%	min^{-1}	Nm	kW	%	min^{-1}	Nm	kW	%	
3.9	718.3	1035.0	81.9	95	359.2	1150.0	45.5	95	230.9	1252.2	31.9	95	128.3	1252.2	17.7	95	180 (B5) 160 (B5) 132 (B5) 112 (B5) 100 (B5)
4.5	618.0	1080.0	73.6	95	309.0	1200.0	40.9	95	198.6	1306.7	28.6	95	110.3	1306.7	15.9	95	
5.9	478.3	1440.0	75.9	95	239.1	1600.0	42.2	95	153.7	1742.2	29.5	95	85.4	1742.2	16.4	95	
6.8	411.4	1458.0	66.1	95	205.7	1620.0	36.7	95	132.2	1764.0	25.7	95	73.5	1764.0	14.3	95	
7.8	359.7	1215.0	48.2	95	179.8	1350.0	26.8	95	115.6	1470.0	18.7	95	64.2	1470.0	10.4	95	
9.0	311.2	1530.0	52.5	95	155.6	1700.0	29.2	95	100.0	1851.1	20.4	95	55.6	1851.1	11.3	95	
10.0	279.2	1530.0	47.1	95	139.6	1700.0	26.2	95	89.7	1851.1	18.3	95	49.9	1851.1	10.2	95	
11.7	239.5	1575.0	41.6	95	119.7	1750.0	23.1	95	77.0	1905.6	16.2	95	42.8	1905.6	9.0	95	
13.2	212.1	1575.0	36.8	95	106.0	1750.0	20.5	95	68.2	1905.6	14.3	95	37.9	1905.6	8.0	95	
14.3	195.8	1620.0	35.0	95	97.9	1800.0	19.4	95	62.9	1960.0	13.6	95	35.0	1960.0	7.6	95	
16.3	171.5	1620.0	30.6	95	85.8	1800.0	17.0	95	55.1	1960.0	11.9	95	30.6	1960.0	6.6	95	
17.5	160.0	1620.0	28.6	95	80.0	1800.0	15.9	95	51.4	1960.0	11.1	95	28.6	1960.0	6.2	95	
19.9	140.7	1350.0	20.9	95	70.4	1500.0	11.6	95	45.2	1633.3	8.1	95	25.1	1633.3	4.5	95	
21.3	131.3	1395.0	20.2	95	65.6	1550.0	11.2	95	42.2	1687.8	7.8	95	23.4	1687.8	4.4	95	
23.6	118.8	1620.0	21.2	95	59.4	1800.0	11.8	95	38.2	1960.0	8.3	95	21.2	1960.0	4.6	95	
26.1	107.2	1440.0	17.0	95	53.6	1600.0	9.4	95	34.4	1742.2	6.6	95	19.1	1742.2	3.7	95	
28.7	97.5	1440.0	15.5	95	48.8	1600.0	8.6	95	31.3	1742.2	6.0	95	17.4	1742.2	3.3	95	
31.8	87.9	1440.0	14.0	95	44.0	1600.0	7.8	95	28.3	1742.2	5.4	95	15.7	1742.2	3.02	95	
35.0	80.0	1440.0	12.7	95	40.0	1600.0	7.1	95	25.7	1742.2	4.9	95	14.3	1742.2	2.74	95	
38.3	73.1	1485.0	12.0	95	36.5	1650.0	6.6	95	23.5	1796.7	4.7	95	13.1	1796.7	2.58	95	
40.1	69.8	1035.0	8.0	95	34.9	1150.0	4.4	95	22.4	1252.2	3.1	95	12.5	1252.2	1.72	95	
44.1	63.5	1035.0	7.2	95	31.8	1150.0	4.0	95	20.4	1252.2	2.8	95	11.3	1252.2	1.57	95	
48.2	58.0	1035.0	6.6	95	29.0	1150.0	3.7	95	18.7	1252.2	2.6	95	10.4	1252.2	1.43	95	

AR 90/3



48

23.0	121.9	1575.0	21.6	93	60.9	1750.0	12.0	93	39.2	1905.6	8.4	93	21.8	1905.6	4.67	93	112 (B5) 100 (B5) 90 (B5) 80 (B5)
28.8	97.4	1575.0	17.3	93	48.7	1750.0	9.6	93	31.3	1905.6	6.7	93	17.4	1905.6	3.73	93	
32.3	86.6	1575.0	15.4	93	43.3	1750.0	8.5	93	27.9	1905.6	6.0	93	15.5	1905.6	3.32	93	
34.3	81.6	1575.0	14.5	93	40.8	1750.0	8.0	93	26.2	1905.6	5.6	93	14.6	1905.6	3.13	93	
42.9	65.2	1575.0	11.6	93	32.6	1750.0	6.4	93	21.0	1905.6	4.5	93	11.6	1905.6	2.50	93	
48.2	58.0	1575.0	10.3	93	29.0	1750.0	5.7	93	18.7	1905.6	4.0	93	10.4	1905.6	2.22	93	
52.3	53.5	1575.0	9.5	93	26.8	1750.0	5.3	93	17.2	1905.6	3.7	93	9.6	1905.6	2.05	93	
61.8	45.3	1620.0	8.3	93	22.7	1800.0	4.6	93	14.6	1960.0	3.2	93	8.1	1960.0	1.79	93	
66.3	42.2	1620.0	7.7	93	21.1	1800.0	4.3	93	13.6	1960.0	3.0	93	7.5	1960.0	1.66	93	
71.5	39.1	1620.0	7.1	93	19.6	1800.0	4.0	93	12.6	1960.0	2.8	93	7.0	1960.0	1.54	93	
75.3	37.2	1620.0	6.8	93	18.6	1800.0	3.8	93	12.0	1960.0	2.6	93	6.6	1960.0	1.47	93	
77.3	36.2	1620.0	6.6	93	18.1	1800.0	3.7	93	11.6	1960.0	2.6	93	6.5	1960.0	1.43	93	
86.0	32.6	1620.0	5.9	93	16.3	1800.0	3.3	93	10.5	1960.0	2.3	93	5.8	1960.0	1.28	93	
92.2	30.4	1620.0	5.5	93	15.2	1800.0	3.1	93	9.8	1960.0	2.2	93	5.4	1960.0	1.20	93	
100.1	28.0	1665.0	5.2	93	14.0	1850.0	2.9	93	9.0	2014.4	2.0	93	5.0	2014.4	1.13	93	
106.8	26.2	1665.0	4.9	93	13.1	1850.0	2.7	93	8.4	2014.4	1.9	93	4.7	2014.4	1.06	93	
115.4	24.3	1710.0	4.7	93	12.1	1900.0	2.6	93	7.8	2068.9	1.8	93	4.3	2068.9	1.01	93	
126.4	22.2	1710.0	4.3	93	11.1	1900.0	2.4	93	7.1	2068.9	1.7	93	4.0	2068.9	0.92	93	
135.0	20.7	1710.0	4.0	93	10.4	1900.0	2.2	93	6.7	2068.9	1.6	93	3.7	2068.9	0.86	93	
149.4	18.7	1710.0	3.6	93	9.4	1900.0	2.0	93	6.0	2068.9	1.4	93	3.3	2068.9	0.78	93	
164.5	17.0	1755.0	3.4	93	8.5	1950.0	1.9	93	5.5	2123.3	1.3	93	3.0	2123.3	0.73	93	
188.6	14.8	1755.0	2.9	93	7.4	1950.0	1.6	93	4.8	2123.3	1.1	93	2.7	2123.3	0.63	93	
217.6	12.9	1755.0	2.5	93	6.4	1950.0	1.4	93	4.1	2123.3	1.0	93	2.3	2123.3	0.55	93	
237.5	11.8	1125.0	1.5	93	5.9	1250.0	0.83	93	3.8	1361.1	0.58	93	2.1	1361.1	0.32	93	
274.0	10.2	1125.0	1.3	93	5.1	1250.0	0.72	93	3.3	1361.1	0.50	93	1.8	1361.1	0.28	93	

Tous les rapports / Todas las relaciones / Todas as relações

P_{tN} [kW]	90/2	18.0
	90/3	12.4

N.B. Pour les réducteurs caractérisés par le double bord dans la colonne des puissances, il est nécessaire de vérifier l'échange thermique du réducteur (comme au paragraphe 1.5-A). Pour toute autre information, contacter le Service Technique STM.

Nota: Para los reductores que se evidencian por el doble borde en la columna de las potencias es necesario verificar el intercambio térmico del reductor (como en el párr. 1.5-A). Para mayores informaciones, contactar la oficina técnica STM.

OBS. Para redutores marcados com duplo contorno na coluna das potências é necessário controlar a sua troca térmica (cf. Par. 1.5-A). Para maiores informações contacte o depto. Técnico STM.



1.6 Performances réducteurs AR

1.6 Prestaciones reductores AR

1.6 Desempenhos redutores AR

AR 100/1

Kg 55

ir	n ₁ = 2800 min ⁻¹				n ₁ = 1400 min ⁻¹				n ₁ = 900 min ⁻¹				n ₁ = 500 min ⁻¹				IEC	
	n ₂ min ⁻¹	T _{2M} Nm	P kW	RD %	n ₂ min ⁻¹	T _{2M} Nm	P kW	RD %	n ₂ min ⁻¹	T _{2M} Nm	P kW	RD %	n ₂ min ⁻¹	T _{2M} Nm	P kW	RD %		
1.3	2178	480	112.8	97	1089	480	56.4	97	700	480	36.3	97	389	480	20.2	97	200 (B5)	
1.9	1447	490	76.5	97	723	490	38.3	97	465	490	24.6	97	258	490	13.7	97		180 (B5)
2.2	1289	600	83.5	97	644	600	41.7	97	414	600	26.8	97	230	600	14.9	97		
3.0	947	600	61.3	97	474	600	30.7	97	304	600	19.7	97	169	600	11.0	97		160 (B5)
3.5	812	600	52.6	97	406	600	26.3	97	261	600	16.9	97	145	600	9.4	97		
3.9	717	600	46.4	97	359	600	23.2	97	230	600	14.9	97	128	600	8.3	97		132 (B5-B14)
5.4	515	530	29.5	97	257	530	14.7	97	166	550	9.8	97	92	550	5.5	97		
5.9	472	530	27.0	97	236	530	13.5	97	152	550	9.0	97	84	550	5.0	97		112 (B5)
6.9	404	460	20.1	97	202	480	10.5	97	130	500	7.0	97	72	550	4.3	97		
7.5	373	450	18.1	97	187	470	9.5	97	120	500	6.5	97	67	500	3.6	97		100 (B5)

AR 100/2

Kg 60

2.4	1148	913	115	95	574	1085	69	95	369	1212	49	95	205	1670	38	95	200 (B5)	
2.7	1026	956	108	95	513	1136	64	95	330	1269	46	95	183	1747	35	95		180 (B5)
3.7	753	1026	85	95	376	1221	51	95	242	1363	36	95	134	1878	28	95		
4.9	569	1085	68	95	285	1291	40	95	183	1441	29	95	102	1930	22	95		160 (B5)
6.9	409	1136	51	95	204	1351	30	95	131	1509	22	95	73	1930	15.5	95		
7.5	375	1181	49	95	187	1404	29	95	120	1568	21	95	67	1930	14.2	95		132 (B5-B14)
7.9	354	1221	48	95	177	1452	28	95	114	1621	20	95	63	1930	13.5	95		
8.9	316	1257	44	95	158	1495	26	95	101	1670	18.7	95	56	1930	12.0	95		112 (B5)
9.9	284	1291	40	95	142	1535	24	95	91	1714	17.2	95	51	1930	10.8	95		
11.1	253	1322	37	95	126	1572	22	95	81	1755	15.7	95	45	1930	9.6	95		100 (B5)
12.1	232	1351	35	95	116	1606	21	95	75	1794	14.7	95	41	1930	8.8	95		
14.1	199	1404	31	95	99	1670	18.3	95	64	1865	13.1	95	35	1930	7.5	95	100 (B5)	
15.9	176	1352	28	95	88	1726	16.7	95	56	1928	12.0	95	31	1930	6.7	95		
17.6	159	1395	26	95	80	1778	15.6	95	51	1930	10.9	95	28	1930	6.0	95	100 (B5)	
19.9	141	1535	24	95	70	1825	14.1	95	45	1930	9.6	95	25	1930	5.3	95		
22.2	126	1572	22	95	63	1869	13.0	95	41	1930	8.6	95	23	1930	4.8	95	100 (B5)	
24.2	116	1623	21	95	58	1930	12.3	95	37	1930	7.9	95	21	1930	4.4	95		
28.3	99	1623	17.7	95	50	1930	10.5	95	32	1930	6.8	95	18	1930	3.8	95	100 (B5)	
30.3	93	1623	16.6	95	46	1930	9.8	95	30	1930	6.3	95	17	1930	3.5	95		
35.3	79	1623	14.2	95	40	1930	8.4	95	25	1930	5.4	95	14	1930	3.0	95	100 (B5)	
38.3	73	1623	13.1	95	37	1930	7.8	95	24	1930	5.0	95	13	1930	2.8	95		

AR 100/3

Kg 60

29.1	96	1669	18.1	93	48	1985	10.7	93	31	1985	6.9	93	17	1985	3.8	93	132 (B5)	
32.5	86	1726	16.8	93	43	1985	9.6	93	28	1985	6.2	93	15	1985	3.4	93		112 (B5)
36.4	77	1777	15.4	93	38	1985	8.6	93	25	1985	5.5	93	14	1985	3.1	93		
40.6	69	1825	14.2	93	35	1985	7.7	93	22	1985	5.0	93	12	1985	2.8	93		100 (B5)
45.2	62	1879	13.1	93	31	1985	6.9	93	20	1985	4.4	93	11	1985	2.5	93		
52.8	53	1930	11.5	93	26	1985	5.9	93	17	1985	3.8	93	9.5	1985	2.1	93		90 (B5)
56.7	49	1985	11.0	93	25	1985	5.5	93	16	1985	3.5	93	8.8	1985	2.0	93		
64.5	43	1985	9.7	93	22	1985	4.9	93	14	1985	3.1	93	7.8	1985	1.7	93		90 (B5)
73.6	38	1985	8.5	93	19	1985	4.3	93	12	1985	2.7	93	6.8	1985	1.5	93		
78.9	35	1985	7.9	93	18	1985	4.0	93	11	1985	2.5	93	6.3	1985	1.4	93		90 (B5)
91.9	30	1985	6.7	93	15	1985	3.4	93	9.7	1985	2.2	93	5.4	1985	1.2	93		
98.6	28	1985	6.3	93	14	1985	3.2	93	9.1	1985	2.0	93	5.1	1985	1.1	93	90 (B5)	
117.8	24	1985	5.3	93	12	1985	2.7	93	7.6	1985	1.7	93	4.2	1985	0.95	93		
129.5	22	1985	4.8	93	11	1985	2.4	93	7.0	1985	1.6	93	3.9	1985	0.86	93	90 (B5)	
147.2	19	1985	4.3	93	9.5	1985	2.1	93	6.1	1985	1.4	93	3.4	1985	0.76	93		
161.8	17	1985	3.9	93	8.7	1985	1.9	93	5.6	1985	1.2	93	3.1	1985	0.69	93	90 (B5)	
177.1	16	1985	3.5	93	7.9	1985	1.8	93	5.1	1985	1.1	93	2.8	1985	0.63	93		

Pt _N [kW]	Tous les rapports / Todas las relaciones / Todas as relações	
	100/1	21.0
	100/2	23.0
100/3	18.5	

N.B. Pour les réducteurs caractérisés par le double bord dans la colonne des puissances, il est nécessaire de vérifier l'échange thermique du réducteur (comme au paragraphe 1.5-A). Pour toute autre information, contacter le Service Technique STM.

Nota: Para los reductores que se evidencian por el doble borde en la columna de las potencias es necesario verificar el intercambio térmico del reductor (como en el párr. 1.5-A). Para mayores informaciones, contactar la oficina técnica STM.

OBS. Para reductores marcados com duplo contorno na coluna das potências é necessário controlar a sua troca térmica (cf. Par. 1.5-A). Para maiores informações contacte o depto. Técnico STM.



1.6 Performances réducteurs AR

1.6 Prestaciones reductores AR

1.6 Desempenhos redutores AR

AR 110/2



85

ir	$n_1 = 2800 \text{ min}^{-1}$				$n_1 = 1400 \text{ min}^{-1}$				$n_1 = 900 \text{ min}^{-1}$				$n_1 = 500 \text{ min}^{-1}$				IEC
	n_2	T_{2M}	P	RD	n_2	T_{2M}	P	RD	n_2	T_{2M}	P	RD	n_2	T_{2M}	P	RD	
	min^{-1}	Nm	kW	%	min^{-1}	Nm	kW	%	min^{-1}	Nm	kW	%	min^{-1}	Nm	kW	%	
3,8	738,2	1575,0	128,2	95	369,1	1750,0	71,2	95	237,3	1750,0	45,8	95	131,8	1750,0	25,4	95	200 (B5)
5,7	490,4	1575,0	85,1	95	245,2	1750,0	47,3	95	157,6	1750,0	30,4	95	87,6	1750,0	16,9	95	
6,5	429,0	2070,0	97,9	95	214,5	2300,0	54,4	95	137,9	2300,0	35,0	95	76,6	2300,0	19,4	95	
7,2	390,0	1800,0	77,4	95	195,0	2000,0	43,0	95	125,4	2000,0	27,6	95	69,7	2000,0	15,4	95	
7,9	352,3	1800,0	69,9	95	176,1	2000,0	38,8	95	113,2	2000,0	25,0	95	62,9	2000,0	13,9	95	
9,8	284,9	2160,0	67,8	95	142,5	2400,0	37,7	95	91,6	2400,0	24,2	95	50,9	2400,0	13,5	95	
11,0	253,9	2160,0	60,4	95	126,9	2400,0	33,6	95	81,6	2400,0	21,6	95	45,3	2400,0	12,0	95	
12,1	230,8	2070,0	52,7	95	115,4	2300,0	29,3	95	74,2	2300,0	18,8	95	41,2	2300,0	10,5	95	
15,0	186,5	2250,0	46,3	95	93,3	2500,0	25,7	95	60,0	2500,0	16,5	95	33,3	2500,0	9,2	95	
16,5	169,6	2070,0	38,7	95	84,8	2300,0	21,5	95	54,5	2300,0	13,8	95	30,3	2300,0	7,7	95	
17,5	159,9	2250,0	39,6	95	79,9	2500,0	22,0	95	51,4	2500,0	14,2	95	28,5	2500,0	7,9	95	
19,8	141,2	2250,0	35,0	95	70,6	2500,0	19,5	95	45,4	2500,0	12,5	95	25,2	2500,0	7,0	95	
21,8	128,4	2070,0	29,3	95	64,2	2300,0	16,3	95	41,3	2300,0	10,5	95	22,9	2300,0	5,8	95	
24,1	116,0	2070,0	26,5	95	58,0	2300,0	14,7	95	37,3	2300,0	9,5	95	20,7	2300,0	5,3	95	
27,6	101,4	2340,0	26,2	95	50,7	2600,0	14,5	95	32,6	2600,0	9,3	95	18,1	2600,0	5,2	95	
30,1	93,0	2340,0	24,0	95	46,5	2600,0	13,3	95	29,9	2600,0	8,6	95	16,6	2600,0	4,8	95	
33,1	84,5	2160,0	20,1	95	42,3	2400,0	11,2	95	27,2	2400,0	7,2	95	15,1	2400,0	4,0	95	
35,1	79,7	2160,0	19,0	95	39,8	2400,0	10,5	95	25,6	2400,0	6,8	95	14,2	2400,0	3,8	95	
38,7	72,4	2160,0	17,2	95	36,2	2400,0	9,6	95	23,3	2400,0	6,2	95	12,9	2400,0	3,4	95	
41,9	66,9	2160,0	15,9	95	33,4	2400,0	8,8	95	21,5	2400,0	5,7	95	11,9	2400,0	3,2	95	
46,4	60,4	2070,0	13,8	95	30,2	2300,0	7,7	95	19,4	2300,0	4,9	95	10,8	2300,0	2,7	95	

AR 110/3



85

23,6	118,8	2250,0	30,1	93	59,4	2500,0	16,7	93	38,2	2500,0	10,7	93	21,2	2500,0	6,0	93	132 (B5)
27,4	102,2	2250,0	25,9	93	51,1	2500,0	14,4	93	32,8	2500,0	9,2	93	18,2	2500,0	5,1	93	
32,8	85,3	2250,0	21,6	93	42,6	2500,0	12,0	93	27,4	2500,0	7,7	93	15,2	2500,0	4,3	93	
36,1	77,6	2250,0	19,6	93	38,8	2500,0	10,9	93	24,9	2500,0	7,0	93	13,8	2500,0	3,9	93	
42,0	66,7	2250,0	16,9	93	33,4	2500,0	9,4	93	21,4	2500,0	6,0	93	11,9	2500,0	3,4	93	
47,1	59,5	2340,0	15,7	93	29,7	2600,0	8,7	93	19,1	2600,0	5,6	93	10,6	2600,0	3,1	93	
51,8	54,1	2340,0	14,2	93	27,0	2600,0	7,9	93	17,4	2600,0	5,1	93	9,7	2600,0	2,8	93	
55,5	50,5	2340,0	13,3	93	25,2	2600,0	7,4	93	16,2	2600,0	4,7	93	9,0	2600,0	2,6	93	
61,8	45,3	2340,0	11,9	93	22,6	2600,0	6,6	93	14,6	2600,0	4,3	93	8,1	2600,0	2,4	93	
65,6	42,7	2340,0	11,3	93	21,4	2600,0	6,3	93	13,7	2600,0	4,0	93	7,6	2600,0	2,2	93	
72,3	38,7	2340,0	10,2	93	19,4	2600,0	5,7	93	12,4	2600,0	3,6	93	6,9	2600,0	2,0	93	
77,5	36,1	2340,0	9,5	93	18,1	2600,0	5,3	93	11,6	2600,0	3,4	93	6,5	2600,0	1,9	93	
81,4	34,4	2430,0	9,4	93	17,2	2700,0	5,2	93	11,1	2700,0	3,4	93	6,1	2700,0	1,9	93	
88,2	31,8	2430,0	8,7	93	15,9	2700,0	4,8	93	10,2	2700,0	3,1	93	5,7	2700,0	1,7	93	
94,9	29,5	2430,0	8,1	93	14,8	2700,0	4,5	93	9,5	2700,0	2,9	93	5,3	2700,0	1,6	93	
100,7	27,8	2430,0	7,6	93	13,9	2700,0	4,2	93	8,9	2700,0	2,7	93	5,0	2700,0	1,5	93	
107,9	25,9	2430,0	7,1	93	13,0	2700,0	3,9	93	8,3	2700,0	2,5	93	4,6	2700,0	1,4	93	
115,7	24,2	2430,0	6,6	93	12,1	2700,0	3,7	93	7,8	2700,0	2,4	93	4,3	2700,0	1,3	93	
127,2	22,0	2430,0	6,0	93	11,0	2700,0	3,3	93	7,1	2700,0	2,2	93	3,9	2700,0	1,2	93	
139,2	20,1	2430,0	5,5	93	10,1	2700,0	3,1	93	6,5	2700,0	2,0	93	3,6	2700,0	1,1	93	
145,3	19,3	2430,0	5,3	93	9,6	2700,0	2,9	93	6,2	2700,0	1,9	93	3,4	2700,0	1,0	93	
154,1	18,2	2520,0	5,2	93	9,1	2800,0	2,9	93	5,8	2800,0	1,8	93	3,2	2800,0	1,0	93	
161,1	17,4	2520,0	4,9	93	8,7	2800,0	2,7	93	5,6	2800,0	1,8	93	3,1	2800,0	1,0	93	
177,1	15,8	2520,0	4,5	93	7,9	2800,0	2,5	93	5,1	2800,0	1,6	93	2,8	2800,0	0,89	93	
193,8	14,4	2520,0	4,1	93	7,2	2800,0	2,3	93	4,6	2800,0	1,5	93	2,6	2800,0	0,81	93	
214,6	13,0	2520,0	3,7	93	6,5	2800,0	2,1	93	4,2	2800,0	1,3	93	2,3	2800,0	0,73	93	

P_{tN} [kW]	Tous les rapports / Todas las relaciones / Todas as relações	
	110/2	25.5
	110/3	19.5

N.B. Pour les réducteurs caractérisés par le double bord dans la colonne des puissances, il est nécessaire de vérifier l'échange thermique du réducteur (comme au paragraphe 1.5-A). Pour toute autre information, contacter le Service Technique STM.

Nota: Para los reductores que se evidencian por el doble borde en la columna de las potencias es necesario verificar el intercambio térmico del reductor (como en el párr. 1.5-A). Para mayores informaciones, contactar la oficina técnica STM.

OBS. Para redutores marcados com duplo contorno na coluna das potências é necessário controlar a sua troca térmica (cf. Par. 1.5-A). Para maiores informações contacte o depto. Técnico STM.



1.6 Performances réducteurs AR

1.6 Prestaciones reductores AR

1.6 Desempenhos redutores AR

AR 120/2



155

ir	n ₁ = 2800 min ⁻¹				n ₁ = 1400 min ⁻¹				n ₁ = 900 min ⁻¹				n ₁ = 500 min ⁻¹				IEC
	n ₂	T _{2M}	P	RD	n ₂	T _{2M}	P	RD	n ₂	T _{2M}	P	RD	n ₂	T _{2M}	P	RD	
	min ⁻¹	Nm	kW	%	min ⁻¹	Nm	kW	%	min ⁻¹	Nm	kW	%	min ⁻¹	Nm	kW	%	
2.8	1005	1380	152	95	503	1700	94	95	323	1700	60	95	179	1700	34	95	225 (B5) 200 (B5) 180 (B5) 160 (B5) 132 (B5-B14) 112 (B5) 100(B5)
3.9	726	1380	110	95	363	1700	68	95	233	1700	44	95	130	1700	24	95	
5.2	537	1460	86	95	268	1800	53	95	172	1800	34	95	96	1800	19	95	
6.1	457	1620	81	95	229	2000	50	95	147	2280	37	95	82	2720	24	95	
7.7	366	1780	72	95	183	2200	44	95	118	2500	32	95	65	3000	22	95	
8.5	330	2030	74	95	165	2500	45	95	106	2850	33	95	59	3000	21	95	
10.6	264	2270	66	95	132	2280	41	95	85	3000	29	95	47	3000	17	95	
11.5	244	2430	65	95	122	3000	40	95	78	3000	28	95	44	3000	16	95	
14.1	199	2430	53	95	100	3000	33	95	64	3000	23	95	36	3000	13	95	
17.7	158	2430	42	95	79	3000	26	95	51	3000	18	95	28	3000	10	95	
19.3	145	2430	39	95	73	3000	24	95	47	3000	17	95	26	3000	9.4	95	
21.0	133	2430	36	95	67	3000	22	95	43	3000	16	95	24	3000	8.6	95	
22.1	127	2430	34	95	63	3000	21	95	41	3000	15	95	23	3000	8.2	95	
23.1	121	2430	32	95	61	3000	20	95	39	3000	14	95	22	3000	7.8	95	
24.0	116	2430	31	95	58	3000	19	95	37	3000	14	95	21	3000	7.5	95	
27.0	104	2430	28	95	52	3000	17	95	33	3000	12	95	19	3000	6.7	95	
28.9	97	2430	26	95	48	3000	16	95	31	3000	11	95	17	3000	6.3	95	
29.6	95	2430	25	95	47	3000	16	95	30	3000	11	95	17	3000	6.1	95	
33.7	83	2430	22	95	41	3000	14	95	27	3000	10	95	15	3000	5.4	95	
37.0	76	2430	20	95	38	3000	12	95	24	3000	8.8	95	14	3000	4.9	95	

AR 120/3



155

40.7	69	2550	20	93	34	3300	13	93	22	3300	8.2	93	12	3300	4.6	93	132 (B5) 112 (B5) 100 (B5) 90 (B5)
45.7	61	2640	18	93	31	3300	11	93	20	3300	7.3	93	11	3300	4.1	93	
50.9	55	2700	17	93	28	3300	10	93	18	3300	6.6	93	10	3300	3.7	93	
57.1	49	2760	15	93	25	3300	9.1	93	16	3300	5.9	93	8.8	3300	3.3	93	
62.2	45	2840	14	93	23	3300	8.4	93	14	3300	5.4	93	8.0	3300	3.0	93	
72.6	39	2900	13	93	19	3300	7.2	93	12	3300	4.6	93	6.9	3300	2.6	93	
77.7	36	2960	12	93	18	3300	6.7	93	12	3300	4.3	93	6.4	3300	2.4	93	
82.2	34	3040	12	93	17	3300	6.3	93	11	3300	4.1	93	6.1	3300	2.3	93	
90.7	31	3100	11	93	15	3300	5.7	93	10	3300	3.7	93	5.5	3300	2.0	93	
102.6	27	3180	10	93	14	3300	5.1	93	8.8	3300	3.3	93	4.9	3300	1.8	93	
114.4	24	3250	9.0	93	12	3300	4.5	93	7.9	3300	2.9	93	4.4	3300	1.6	93	
124.9	22	3300	8.3	93	11	3300	4.2	93	7.2	3300	2.7	93	4.0	3300	1.5	93	
142.9	20	3300	7.3	93	10	3300	3.6	93	6.3	3300	2.3	93	3.5	3300	1.3	93	
156.0	18	3300	6.7	93	9.0	3300	3.3	93	5.8	3300	2.1	93	3.2	3300	1.2	93	
175.7	16	3300	5.9	93	8.0	3300	3.0	93	5.1	3300	1.9	93	2.8	3300	1.1	93	
182.0	15	3300	5.7	93	7.7	3300	2.9	93	4.9	3300	1.8	93	2.7	3300	1.0	93	
197.1	14	3300	5.3	93	7.1	3300	2.6	93	4.6	3300	1.7	93	2.5	3300	0.9	93	
205.0	14	3300	5.1	93	6.8	3300	2.5	93	4.4	3300	1.6	93	2.4	3300	0.9	93	
222.0	13	3300	4.7	93	6.3	3300	2.3	93	4.1	3300	1.5	93	2.3	3300	0.8	93	
256.0	11	3300	4.1	93	5.5	3300	2.0	93	3.5	3300	1.3	93	2.0	3300	0.7	93	
277.3	10	3300	3.8	93	5.0	3300	1.9	93	3.2	3300	1.2	93	1.8	3300	0.7	93	

Pt _N [kW]	Tous les rapports / Todas las relaciones / Todas as relações	
	120/2	33.0
	120/3	22.1

N.B. Pour les réducteurs caractérisés par le double bord dans la colonne des puissances, il est nécessaire de vérifier l'échange thermique du réducteur (comme au paragraphe 1.5-A). Pour toute autre information, contacter le Service Technique STM.

Nota: Para los reductores que se evidencian por el doble borde en la columna de las potencias es necesario verificar el intercambio térmico del reductor (como en el párr. 1.5-A). Para mayores informaciones, contactar la oficina técnica STM.

OBS. Para redutores marcados com duplo contorno na coluna das potências é necessário controlar a sua troca térmica (cf. Par. 1.5-A). Para maiores informações contacte o depto. Técnico STM.



1.6 Performances réducteurs AR

1.6 Prestaciones reductores AR

1.6 Desempenhos redutores AR

AR 140/2



195

ir	$n_1 = 2800 \text{ min}^{-1}$				$n_1 = 1400 \text{ min}^{-1}$				$n_1 = 900 \text{ min}^{-1}$				$n_1 = 500 \text{ min}^{-1}$				IEC
	n_2	T_{2M}	P	RD	n_2	T_{2M}	P	RD	n_2	T_{2M}	P	RD	n_2	T_{2M}	P	RD	
	min^{-1}	Nm	kW	%	min^{-1}	Nm	kW	%	min^{-1}	Nm	kW	%	min^{-1}	Nm	kW	%	
5.4	521.0	2160.0	124.1	95	260.5	2400.0	68.9	95	167.5	2613.3	48.2	95	93.0	2613.3	26.8	95	250 (B5) 225 (B5)
6.9	408.3	2700.0	121.5	95	204.2	3000.0	67.5	95	131.3	3266.7	47.3	95	72.9	3266.7	26.3	95	
9.0	311.4	3870.0	132.8	95	155.7	4300.0	73.8	95	100.1	4682.2	51.7	95	55.6	4682.2	28.7	95	200 (B5)
11.5	244.0	3870.0	104.1	95	122.0	4300.0	57.8	95	78.4	4682.2	40.5	95	43.6	4682.2	22.5	95	
15.3	182.9	3870.0	78.0	95	91.4	4300.0	43.3	95	58.8	4682.2	30.3	95	32.7	4682.2	16.9	95	180 (B5)
17.4	160.6	3870.0	68.5	95	80.3	4300.0	38.1	95	51.6	4682.2	26.6	95	28.7	4682.2	14.8	95	
23.3	120.3	3870.0	51.3	95	60.2	4300.0	28.5	95	38.7	4682.2	20.0	95	21.5	4682.2	11.1	95	160 (B5)
27.4	102.3	3870.0	43.6	95	51.1	4300.0	24.2	95	32.9	4682.2	17.0	95	18.3	4682.2	9.4	95	
30.0	93.3	3870.0	39.8	95	46.7	4300.0	22.1	95	30.0	4682.2	15.5	95	16.7	4682.2	8.6	95	132 (B5)
36.5	76.7	3870.0	32.7	95	38.3	4300.0	18.2	95	24.6	4682.2	12.7	95	13.7	4682.2	7.1	95	
46.0	60.9	3870.0	26.0	95	30.5	4300.0	14.4	95	19.6	4682.2	10.1	95	10.9	4682.2	5.6	95	

AR 140/3



195

47.1	59.5	3870.0	25.9	93	29.7	4300.0	14.4	93	19.1	4682.2	10.1	93	10.6	4682.2	5.60	93	225 (B5)
60.1	46.6	3870.0	20.3	93	23.3	4300.0	11.3	93	15.0	4682.2	7.9	93	8.3	4682.2	4.39	93	
73.9	37.9	3870.0	16.5	93	18.9	4300.0	9.2	93	12.2	4682.2	6.4	93	6.8	4682.2	3.57	93	200 (B5)
80.1	34.9	3870.0	15.2	93	17.5	4300.0	8.5	93	11.2	4682.2	5.9	93	6.2	4682.2	3.29	93	
94.3	29.7	3870.0	12.9	93	14.8	4300.0	7.2	93	9.5	4682.2	5.0	93	5.3	4682.2	2.80	93	180 (B5)
103.3	27.1	3870.0	11.8	93	13.5	4300.0	6.6	93	8.7	4682.2	4.6	93	4.8	4682.2	2.55	93	
110.6	25.3	3870.0	11.0	93	12.7	4300.0	6.1	93	8.1	4682.2	4.3	93	4.5	4682.2	2.38	93	160 (B5)
119.9	23.3	3870.0	10.2	93	11.7	4300.0	5.7	93	7.5	4682.2	4.0	93	4.2	4682.2	2.20	93	
125.8	22.3	3870.0	9.7	93	11.1	4300.0	5.4	93	7.2	4682.2	3.8	93	4.0	4682.2	2.09	93	132 (B5 - B14)
141.1	19.8	3870.0	8.6	93	9.9	4300.0	4.8	93	6.4	4682.2	3.4	93	3.5	4682.2	1.87	93	
154.6	18.1	3870.0	7.9	93	9.1	4300.0	4.4	93	5.8	4682.2	3.1	93	3.2	4682.2	1.70	93	112 (B5)
168.7	16.6	3870.0	7.2	93	8.3	4300.0	4.0	93	5.3	4682.2	2.8	93	3.0	4682.2	1.56	93	
188.3	14.9	3870.0	6.5	93	7.4	4300.0	3.6	93	4.8	4682.2	2.5	93	2.7	4682.2	1.40	93	100 (B5)
198.5	14.1	3870.0	6.1	93	7.1	4300.0	3.4	93	4.5	4682.2	2.4	93	2.5	4682.2	1.33	93	
217.5	12.9	3870.0	5.6	93	6.4	4300.0	3.1	93	4.1	4682.2	2.2	93	2.3	4682.2	1.21	93	
264.8	10.6	3870.0	4.6	93	5.3	4300.0	2.6	93	3.4	4682.2	1.8	93	1.9	4682.2	1.00	93	

P_{tN} [kW]	Tous les rapports / Todas las relaciones / Todas as relações	
	140/2	45.0
	140/3	38.6

N.B. Pour les réducteurs caractérisés par le double bord dans la colonne des puissances, il est nécessaire de vérifier l'échange thermique du réducteur (comme au paragraphe 1.5-A). Pour toute autre information, contacter le Service Technique STM.

Nota: Para los reductores que se evidencian por el doble borde en la columna de las potencias es necesario verificar el intercambio térmico del reductor (como en el párr. 1.5-A). Para mayores informaciones, contactar la oficina técnica STM.

OBS. Para redutores marcados com duplo contorno na coluna das potências é necessário controlar a sua troca térmica (cf. Par. 1.5-A). Para maiores informações contacte o depto. Técnico STM.



1.7 Performances motoréducteurs

1.7 Prestaciones motorreductores

1.7 Desempenhos motorreductores

n_2 min ⁻¹	ir	T2 Nm	FS'	AM AC	
----------------------------	----	----------	-----	----------	--

0.09 kW	$n_1 = 2740 \text{ min}^{-1}$ $n_1 = 1360 \text{ min}^{-1}$ $n_1 = 860 \text{ min}^{-1}$	56A 2 56B 4 63B 6
----------------	--	-------------------------

806	3.4	1.0	11.8	25/2	56A 2
703	3.9	1.2	10.5	25/2	56A 2
571	4.8	1.4	8.5	25/2	56A 2
453	3.0	1.8	13.6	32/1	56B 4
400	3.4	2.0	5.9	25/2	56B 4
349	3.9	2.3	5.2	25/2	56B 4
302	4.5	2.8	9.6	32/1	56B 4
283	4.8	2.9	4.2	25/2	56B 4
257	5.3	3.2	8.2	32/1	56B 4
243	5.6	3.4	3.6	25/2	56B 4
209	6.5	4.0	5.2	32/1	56B 4
189	7.2	4.3	2.8	25/2	56B 4
156	8.7	5.2	2.3	25/2	56B 4
151	9.0	5.4	2.6	25/2	56B 4
130	10.5	6.3	2.2	25/2	56B 4
101	13.4	8.0	1.9	25/2	56B 4
84	16.2	10	1.5	25/2	56B 4
76	17.9	11	1.4	25/2	56B 4
72	18.9	11	1.7	25/3	56B 4
58	23.4	14	1.4	25/3	56B 4
50	27.2	16	1.3	25/3	56B 4
47	18.1	17.2	3.2	35/2	63B 6
46	59.1	17.6	3.1	35/3	56A 2
43	31.9	19	0.9	25/3	56B 4
40	21.3	20.3	3.0	35/2	63B 6
40	68.1	20.3	2.7	35/3	56A 2
39	35.3	21	0.8	25/3	56B 4
33	41.8	25	0.9	25/3	56B 4
31	43.9	25.8	2.3	35/3	56B 4
27	50.6	29.7	2.0	35/3	56B 4
23	37.2	35.3	3.2	41/2	63B 6
23	59.1	34.7	1.7	35/3	56B 4
20	68.1	40.1	1.5	35/3	56B 4
17.3	49.6	47.1	2.4	41/2	63B 6
17.3	78.6	46.2	1.3	35/3	56B 4
15.8	54.4	50.6	2.4	41/3	63B 6
14.7	92.4	54.3	1.1	35/3	56B 4
14.0	61.3	57.0	2.1	41/3	63B 6
12.5	109.1	64.1	0.9	35/3	56B 4
12.1	70.8	65.8	1.8	41/3	63B 6
10.9	124.3	73.1	0.8	35/3	56B 4
10.4	82.5	76.7	1.6	41/3	63B 6
9.6	89.3	83	2.6	50/3	63B 6
9.5	91.0	84.6	1.4	41/3	63B 6
8.0	107.4	99.8	1.2	41/3	63B 6
7.3	117.6	109	2.0	50/3	63B 6
7.3	118.4	110.0	1.1	41/3	63B 6
6.7	127.5	119	1.8	50/3	63B 6
6.7	128.6	119.5	1.0	41/3	63B 6
6.1	140.0	130.1	0.9	41/3	63B 6
5.9	146.9	137	1.5	50/3	63B 6

n_2 min ⁻¹	ir	T2 Nm	FS'	AM AC	
----------------------------	----	----------	-----	----------	--

0.11 kW	$n_1 = 1360 \text{ min}^{-1}$	56C 4
----------------	-------------------------------	-------

756	1.8	1.3	16.1	32/1	56C 4
648	2.1	1.6	14.4	32/1	56C 4
544	2.5	1.9	12.7	32/1	56C 4
400	3.4	2.5	4.8	25/2	56C 4
349	3.9	2.9	4.3	25/2	56C 4
283	4.8	3.5	3.5	25/2	56C 4
243	5.6	4.1	3.0	25/2	56C 4
189	7.2	5.3	2.3	25/2	56C 4
156	8.7	6.4	1.9	25/2	56C 4
151	9.0	6.6	2.1	25/2	56C 4
130	10.5	7.7	1.8	25/2	56C 4
101	13.4	10	1.5	25/2	56C 4
84	16.2	12	1.3	25/2	56C 4
76	17.9	13	1.1	25/2	56C 4
72	18.9	14	1.4	25/3	56C 4
58	23.4	17	1.1	25/3	56C 4
50	27.2	20	1.0	25/3	56C 4
31.0	43.9	32	1.9	35/3	56C 4
26.9	50.6	36	1.7	35/3	56C 4
23.0	59.1	42	1.4	35/3	56C 4
20.0	68.1	49	1.2	35/3	56C 4
17.3	78.6	56	1.1	35/3	56C 4
14.7	92.4	66	0.9	35/3	56C 4
12.5	109.1	78	0.8	35/3	56C 4
10.9	124.3	89	0.7	35/3	56C 4

0.13 kW	$n_1 = 2750 \text{ min}^{-1}$ $n_1 = 1360 \text{ min}^{-1}$ $n_1 = 860 \text{ min}^{-1}$	56B 2 63A 4 63C 6
----------------	--	-------------------------

1100	2.5	1.1	14.7	32/1	56B 2
917	3.0	1.3	13.2	32/1	56B 2
809	3.4	1.5	11.8	32/1	56B 2
809	3.4	1.5	8.2	25/2	56B 2
756	1.8	1.6	13.6	32/1	63A 4
705	3.9	1.7	7.3	25/2	56B 2
648	2.1	1.9	12.2	32/1	63A 4
573	4.8	2.1	5.9	25/2	56B 2
544	2.5	2.2	10.7	32/1	63A 4
491	5.6	2.4	5.1	25/2	56B 2
453	3.0	2.7	9.4	32/1	63A 4
425	3.2	2.8	17.6	40/1	63A 4
400	3.4	2.9	4.1	25/2	63A 4
349	3.9	3.5	7.5	32/1	63A 4
349	3.9	3.4	3.6	25/2	63A 4
338	4.0	3.5	10.9	35/2	63A 4
316	8.7	3.7	3.3	25/2	56B 2
302	4.5	4.0	6.7	32/1	63A 4
283	4.8	4.2	2.9	25/2	63A 4
262	10.5	4.5	2.9	25/2	56B 2

n_2 min ⁻¹	ir	T2 Nm	FS'	AM AC	
----------------------------	----	----------	-----	----------	--

0.13 kW	$n_1 = 2750 \text{ min}^{-1}$ $n_1 = 1360 \text{ min}^{-1}$ $n_1 = 860 \text{ min}^{-1}$	56B 2 63A 4 63C 6
----------------	--	-------------------------

257	5.3	4.7	5.7	32/1	63A 4
243	5.6	4.9	2.5	25/2	63A 4
221	3.9	5.3	2.4	25/2	63C 6
205	13.4	5.7	2.3	25/2	56B 2
189	7.2	6.2	2.0	25/2	63A 4
170	16.2	6.9	1.9	25/2	56B 2
156	8.7	7.5	1.6	25/2	63A 4
151	9.0	7.8	1.8	25/2	63A 4
132	6.5	9.1	2.5	32/1	63C 6
130	10.5	9.1	1.5	25/2	63A 4
119	7.2	9.9	1.3	25/2	63C 6
101	13.4	12	1.3	25/2	63A 4
86	15.7	14	4.0	35/2	63A 4
84	16.2	14	1.1	25/2	63A 4
76	17.9	16	1.0	25/2	63A 4
75	18.1	16	3.5	35/2	63A 4
58	23.4	20	1.0	25/3	63A 4
54	25.2	22	2.6	35/2	63A 4
50	27.2	23	0.9	25/3	63A 4
47	28.7	25	2.4	35/2	63A 4
41	33.4	29	1.7	35/2	63A 4
36	38.0	33	1.5	35/2	63A 4
30	45.1	39	1.3	35/2	63A 4
27	49.6	43.0	2.4	41/2	63A 4
27	50.6	44	1.4	35/3	63A 4
25	54.4	46.2	2.4	41/3	63A 4
23	59.1	51	1.2	35/3	63A 4
22	61.3	52.0	2.1	41/3	63A 4
20	68.1	59	1.0	35/3	63A 4
19.2	70.8	60.1	1.8	41/3	63A 4
17.5	77.5	66	3.3	50/3	63A 4
17.3	78.6	68	0.9	35/3	63A 4
15.2	89.3	76	2.8	50/3	63A 4
14.9	91.0	77.3	1.4	41/3	63A 4
14.7	92.4	80	0.7	35/3	63A 4
14.0	61.3	82.3	1.5	41/3	63C 6
13.3	102.1	87	2.4	50/3	63A 4
12.7	107.4	91.2	1.2	41/3	63A 4
11.6	117.6	100	2.2	50/3	63A 4
11.5	118.4	100.5	1.1	41/3	63A 4
10.7	127.5	108	2.0	50/3	63A 4
10.6	128.6	109.2	1.0	41/3	63A 4
9.7	140.0	118.9	0.9	41/3	63A 4
9.3	146.9	125	1.7	50/3	63A 4
8.4	102.1	137	1.5	50/3	63C 6
8.0	107.4	144.2	0.8	41/3	63C 6
7.3	117.6	158	1.4	50/3	63C 6
6.7	127.5	171	1.3	50/3	63C 6
5.9	146.9	197	1.1	50/3	63C 6



1.7 Performances motoréducteurs

1.7 Prestaciones motorreductores

1.7 Desempenhos motorreductores

n_2 min ⁻¹	ir	T2 Nm	FS'	AM AC	
----------------------------	----	----------	-----	----------	--

0.18 kW	$n_1 = 2760 \text{ min}^{-1}$	63A 2
	$n_1 = 1370 \text{ min}^{-1}$	63B 4
	$n_1 = 870 \text{ min}^{-1}$	71A 6

1533	1.8	1.1	13.3	32/1	63A 2
1314	2.1	1.3	11.7	32/1	63A 2
1104	2.5	1.5	10.7	32/1	63A 2
920	3.0	1.8	9.6	32/1	63A 2
913	1.5	1.8	19.2	40/1	63B 4
812	3.4	2.1	8.6	32/1	63A 2
761	1.8	2.2	9.9	32/1	63B 4
708	3.9	2.4	7.6	32/1	63A 2
708	3.9	2.3	5.3	25/2	63A 2
652	2.1	2.6	8.8	32/1	63B 4
613	4.5	2.7	6.5	32/1	63A 2
575	4.8	2.8	4.3	25/2	63A 2
548	2.5	3.0	7.8	32/1	63B 4
493	5.6	3.3	3.7	25/2	63A 2
483	1.8	3.4	6.3	32/1	71A 6
457	3.0	3.7	6.8	32/1	63B 4
425	6.5	3.9	4.3	32/1	63A 2
403	3.4	4.1	3.0	25/2	63B 4
383	7.2	4.3	2.9	25/2	63A 2
351	3.9	4.7	5.4	32/1	63B 4
351	3.9	4.6	2.6	25/2	63B 4
317	8.7	5.1	2.4	25/2	63A 2
307	9.0	5.3	2.3	25/2	63A 2
285	4.8	5.7	2.1	25/2	63B 4
263	10.5	6.2	2.1	25/2	63A 2
245	5.6	6.7	1.8	25/2	63B 4
211	6.5	7.9	2.6	32/1	63B 4
190	7.2	8.6	1.4	25/2	63B 4
187	7.3	8.8	5.1	25/2	63B 4
170	16.2	10	1.4	25/2	63A 2
164	5.3	10	2.6	32/1	71A 6
157	8.7	10	1.2	25/2	63B 4
153	5.7	11	3.8	40/1	71A 6
152	9.0	11	1.3	25/2	63B 4
146	18.9	11	1.4	25/3	63A 2
135	10.1	12	4.1	25/2	63B 4
134	6.5	12	1.8	32/1	71A 6
130	10.5	13	1.1	25/2	63B 4
124	7.0	13	2.9	40/1	71A 6
118	23.4	14	1.1	25/3	63A 2
117	11.7	14	3.6	35/2	63B 4
102	13.4	16	0.9	25/2	63B 4
101	13.6	16	3.1	35/2	63B 4
87	15.7	19	2.9	35/2	63B 4
75	18.1	22	2.5	35/2	63B 4
64	21.3	25	2.2	35/2	63B 4
54	25.2	30	1.9	35/2	63B 4
48	28.7	34	1.8	35/2	63B 4
48	28.6	34.1	3.1	41/2	63B 4
43	20.2	37.9	3.0	41/2	71A 6
41	33.4	40	1.3	35/2	63B 4
37	37.2	44.3	2.4	41/2	63B 4
36	38.0	45	1.1	35/2	63B 4
31	43.9	52	1.1	35/3	63B 4

n_2 min ⁻¹	ir	T2 Nm	FS'	AM AC	
----------------------------	----	----------	-----	----------	--

0.18 kW	$n_1 = 2760 \text{ min}^{-1}$	63A 2
	$n_1 = 1370 \text{ min}^{-1}$	63B 4
	$n_1 = 870 \text{ min}^{-1}$	71A 6

30	28.6	53.7	2.1	41/2	71A 6
30	45.1	54	0.9	35/2	63B 4
29	30.2	56.7	3.1	45/2	71A 6
28	49.6	59.1	1.8	41/2	63B 4
27	50.6	60	1.0	35/3	63B 4
25	54.4	63.5	1.7	41/3	63B 4
25	54.3	63	3.4	50/3	63B 4
23	59.1	70	0.9	35/3	63B 4
22	61.3	71.5	1.5	41/3	63B 4
21	65.9	77	2.7	50/3	63B 4
19.5	44.6	82.0	2.4	45/3	71A 6
19.4	70.8	82.6	1.3	41/3	63B 4
19.2	71.5	83	2.6	50/3	63B 4
19.0	45.9	86.2	2.1	45/2	71A 6
17.7	77.5	90	2.4	50/3	63B 4
17.5	49.6	93.1	1.2	41/2	71A 6
16.9	51.6	94.8	2.3	45/3	71A 6
16.6	82.5	96.3	1.1	41/3	63B 4
15.3	89.3	104	2.1	50/3	63B 4
15.1	91.0	106.2	1.0	41/3	63B 4
14.4	60.6	111.4	2.0	45/3	71A 6
13.4	102.1	119	1.7	50/3	63B 4
12.8	107.4	125.3	0.9	41/3	63B 4
12.0	72.4	133.0	1.5	45/3	71A 6
12.0	72.7	134	3.4	60/3	71A 6
11.6	117.6	137	1.6	50/3	63B 4
11.6	118.4	138.2	0.8	41/3	63B 4
11.1	78.6	144	3.2	60/3	71A 6
10.9	79.8	146.6	1.5	45/3	71A 6
10.7	127.5	149	1.5	50/3	63B 4
9.6	90.4	166	2.8	60/3	71A 6
9.5	92.0	169.1	1.3	45/3	71A 6
9.3	146.9	171	1.2	50/3	63B 4
8.7	100.2	184	2.3	60/3	71A 6
8.5	102.1	188	1.1	50/3	71A 6
7.7	113.7	208.9	0.9	45/3	71A 6
7.4	117.6	216	1.0	50/3	71A 6
6.8	128.8	237	1.9	60/3	71A 6
6.8	127.5	234	0.9	50/3	71A 6
6.7	129.1	237.2	0.8	45/3	71A 6
6.1	143.0	263	1.6	60/3	71A 6
5.3	164.1	302	1.4	60/3	71A 6

0.22 kW	$n_1 = 1400 \text{ min}^{-1}$	63C 4
----------------	-------------------------------	-------

1167	1.2	1.7	17.2	40/1	63C 4
933	1.5	2.2	16.0	40/1	63C 4
824	1.7	2.5	16.2	40/1	63C 4
778	1.8	2.6	8.3	32/1	63C 4
667	2.1	3.1	7.4	32/1	63C 4
560	2.5	3.6	6.5	32/1	63C 4

n_2 min ⁻¹	ir	T2 Nm	FS'	AM AC	
----------------------------	----	----------	-----	----------	--

0.22 kW	$n_1 = 1400 \text{ min}^{-1}$	63C 4
----------------	-------------------------------	-------

467	3.0	4.4	5.7	32/1	63C 4
412	3.4	4.9	5.2	32/1	63C 4
412	3.4	4.8	2.5	25/2	63C 4
359	3.9	5.7	4.5	32/1	63C 4
359	3.9	5.6	2.2	25/2	63C 4
311	4.5	6.6	4.0	32/1	63C 4
292	4.8	6.8	1.8	25/2	63C 4
264	5.3	7.7	3.5	32/1	63C 4
250	5.6	8.0	1.5	25/2	63C 4
215	6.5	9.5	2.2	32/1	63C 4
194	7.2	10	1.2	25/2	63C 4
161	8.7	12	1.0	25/2	63C 4
156	9.0	13	1.1	25/2	63C 4
138	10.1	14.4	3.5	25/2	63C 4
133	10.5	15	0.9	25/2	63C 4
120	11.7	16.6	3.0	35/2	63C 4
103	13.6	19.4	2.6	35/2	63C 4
89	15.7	22.4	2.5	35/2	63C 4
77	18.1	25.9	2.1	35/2	63C 4
69	20.2	28.8	3.6	41/2	63C 4
66	21.3	30.4	1.8	35/2	63C 4
59	23.9	34.1	3.1	41/2	63C 4
56	25.2	35.9	1.6	35/2	63C 4
49	28.7	40.9	1.5	35/2	63C 4
49	28.6	40.8	2.6	41/2	63C 4
42	33.4	47.6	1.1	35/2	63C 4
38	37.2	53.0	2.0	41/2	63C 4
37	38.0	54.2	0.9	35/2	63C 4
31	45.1	64.4	0.8	35/2	63C 4
30	46.2	64	3.3	50/3	63C 4
29	48.9	68	0.9	35/3	63C 4
28	49.6	70.7	1.5	41/2	63C 4
28	50.8	71	3.0	50/3	63C 4
26	54.3	76	2.9	50/3	63C 4
26	54.4	75.9	1.4	41/3	63C 4
23	61.3	85.6	1.3	41/3	63C 4
21	65.9	92	2.3	50/3	63C 4
19.8	70.8	98.8	1.1	41/3	63C 4
19.6	71.5	100	2.2	50/3	63C 4
18.1	77.5	108	2.0	50/3	63C 4
17.0	82.5	115.1	1.0	41/3	63C 4
15.7	89.3	125	1.7	50/3	63C 4
15.4	91.0	127.0	0.9	41/3	63C 4
13.7	102.1	142	1.5	50/3	63C 4
11.9	117.6	164	1.3	50/3	63C 4
11.0	127.5	178	1.2	50/3	63C 4
9.5	146.9	205	1.0	50/3	63C 4



1.7 Performances motoréducteurs

1.7 Prestaciones motorreductores

1.7 Desempenhos motorreductores

n_2 min ⁻¹	ir	T2 Nm	FS'	AM AC	
----------------------------	----	----------	-----	----------	--

0.25 kW	$n_1 = 2790 \text{ min}^{-1}$	63B 2
	$n_1 = 1370 \text{ min}^{-1}$	71A 4
	$n_1 = 870 \text{ min}^{-1}$	71B 6

1550	1.8	1.5	9.7	32/1	63B 2
1329	2.1	1.7	8.5	32/1	63B 2
1116	2.5	2.1	7.8	32/1	63B 2
930	3.0	2.5	7.0	32/1	63B 2
821	3.4	2.8	6.2	32/1	63B 2
821	3.4	2.8	4.3	25/2	63B 2
761	1.8	3.0	7.1	32/1	71A 4
715	3.9	3.2	3.8	25/2	63B 2
652	2.1	3.5	6.4	32/1	71A 4
620	4.5	3.7	4.8	32/1	63B 2
581	4.8	3.9	3.1	25/2	63B 2
548	2.5	4.2	5.6	32/1	71A 4
457	3.0	5.1	4.9	32/1	71A 4
429	6.5	5.4	3.1	32/1	63B 2
388	7.2	5.9	2.1	25/2	63B 2
351	3.9	6.6	3.9	32/1	71A 4
348	2.5	6.7	3.6	32/1	71B 6
304	4.5	7.6	3.5	32/1	71A 4
266	10.5	8.5	1.5	25/2	63B 2
258	5.3	9.0	3.0	32/1	71A 4
211	6.5	11	1.9	32/1	71A 4
196	7.0	12	3.2	40/1	71A 4
187	7.3	12	3.7	35/2	71A 4
172	16.2	13	1.0	25/2	63B 2
158	8.7	14	3.5	35/2	71A 4
156	17.9	15	1.0	25/2	63B 2
148	18.9	15	1.0	25/3	63B 2
135	10.1	17	3.0	35/2	71A 4
117	11.7	19	2.6	35/2	71A 4
101	13.6	23	2.2	35/2	71A 4
87	15.7	26	2.1	35/2	71A 4
75	18.1	30	1.8	35/2	71A 4
75	18.3	30.3	3.5	41/2	71A 4
68	20.2	33.4	3.1	41/2	71A 4
64	21.3	35	1.6	35/2	71A 4
57	23.9	39.6	2.7	41/2	71A 4
54	25.2	42	1.4	35/2	71A 4
52	26.6	44.0	3.6	45/2	71A 4
51	27.0	44	1.4	35/3	71A 4
48	28.7	47	1.3	35/2	71A 4
48	28.6	47.3	2.2	41/2	71A 4
45	30.2	50.0	3.2	45/2	71A 4
41	33.4	55	0.9	35/2	71A 4
40	21.5	56.1	3.5	45/2	71B 6
37	37.2	61.6	1.7	41/2	71A 4
37	37.3	61.8	2.8	45/2	71A 4
36	38.0	63	0.8	35/2	71A 4
34	40.5	66	3.2	50/3	71A 4
33	41.4	67.1	3.0	45/3	71A 4
31	44.6	72.3	2.5	45/3	71A 4
30	46.2	75	2.9	50/3	71A 4
30	45.9	76.0	2.2	45/2	71A 4
28	49.6	82.1	1.3	41/2	71A 4
27	50.8	82	2.6	50/3	71A 4

n_2 min ⁻¹	ir	T2 Nm	FS'	AM AC	
----------------------------	----	----------	-----	----------	--

0.25 kW	$n_1 = 2790 \text{ min}^{-1}$	63B 2
	$n_1 = 1370 \text{ min}^{-1}$	71A 4
	$n_1 = 870 \text{ min}^{-1}$	71B 6

27	51.6	83.6	2.4	45/3	71A 4
25	54.4	88.2	1.2	41/3	71A 4
25	54.3	88	2.5	50/3	71A 4
23	60.6	98.2	2.0	45/3	71A 4
22	61.3	99.3	1.1	41/3	71A 4
21	41.4	105.7	2.1	45/3	71B 6
21	65.9	107	1.9	50/3	71A 4
19.4	70.8	114.7	1.0	41/3	71A 4
19.2	71.5	116	1.9	50/3	71A 4
18.9	72.4	117.3	1.5	45/3	71A 4
17.7	77.5	126	1.7	50/3	71A 4
17.2	79.8	129.3	1.5	45/3	71A 4
16.6	82.5	133.7	0.8	41/3	71A 4
15.3	89.3	145	1.5	50/3	71A 4
15.2	90.4	147	3.1	60/3	71A 4
14.9	92.0	149.1	1.3	45/3	71A 4
13.7	100.2	162	2.6	60/3	71A 4
13.4	102.1	165	1.3	50/3	71A 4
12.2	112.2	182	2.5	60/3	71A 4
12.0	113.7	184.3	1.0	45/3	71A 4
11.6	117.6	191	1.1	50/3	71A 4
10.7	127.5	207	1.0	50/3	71A 4
10.6	129.1	209.2	0.9	45/3	71A 4
10.6	128.8	209	2.2	60/3	71A 4
9.6	143.0	232	1.8	60/3	71A 4
9.5	92.0	234.8	0.9	45/3	71B 6
9.3	146.9	238	0.9	50/3	71A 4
8.3	164.1	266	1.6	60/3	71A 4
6.8	128.8	329	1.4	60/3	71B 6
5.3	164.1	419	1.0	60/3	71B 6

0.37 kW	$n_1 = 2790 \text{ min}^{-1}$	63C 2
	$n_1 = 1380 \text{ min}^{-1}$	71B 4
	$n_1 = 910 \text{ min}^{-1}$	80A 6
	$n_1 = 880 \text{ min}^{-1}$	71C 6

1860	1.5	1.8	19.0	40/1	63C 2
1641	1.7	2.1	19.2	40/1	63C 2
1550	1.8	2.2	6.6	32/1	63C 2
1329	2.1	2.6	5.8	32/1	63C 2
1116	2.5	3.1	5.2	32/1	63C 2
930	3.0	3.7	4.7	32/1	63C 2
821	3.4	4.2	4.2	32/1	63C 2
821	3.4	4.1	2.9	25/2	63C 2
767	1.8	4.5	4.9	32/1	71B 4
715	3.9	4.8	3.7	32/1	63C 2
715	3.9	4.7	2.6	25/2	63C 2
657	2.1	5.2	4.3	32/1	71B 4
620	4.5	5.5	3.2	32/1	63C 2
581	4.8	5.8	2.1	25/2	63C 2
552	2.5	6.2	3.8	32/1	71B 4
526	5.3	6.5	2.9	32/1	63C 2
498	5.6	6.7	1.8	25/2	63C 2
460	3.0	7.5	3.4	32/1	71B 4

n_2 min ⁻¹	ir	T2 Nm	FS'	AM AC	
----------------------------	----	----------	-----	----------	--

0.37 kW	$n_1 = 2790 \text{ min}^{-1}$	63C 2
	$n_1 = 1380 \text{ min}^{-1}$	71B 4
	$n_1 = 910 \text{ min}^{-1}$	80A 6
	$n_1 = 880 \text{ min}^{-1}$	71C 6

419	2.1	8.2	2.8	32/1	71C 6
406	3.4	8.4	3.1	32/1	71B 4
388	7.2	8.7	1.4	25/2	63C 2
354	3.9	9.7	2.7	32/1	71B 4
343	4.0	10	3.9	35/2	71B 4
321	8.7	10	1.2	25/2	63C 2
310	9.0	11	1.1	25/2	63C 2
307	4.5	11	2.4	32/1	71B 4
294	4.7	11	3.5	35/2	71B 4
260	5.3	13	2.0	32/1	71B 4
259	3.4	13	2.0	32/1	71C 6
255	5.4	13	3.0	35/2	71B 4
242	5.7	14	2.8	40/1	71B 4
218	6.3	15	2.6	35/2	71B 4
212	6.5	16	1.3	32/1	71B 4
197	7.0	17	2.2	40/1	71B 4
188	7.3	18	2.5	35/2	71B 4
159	8.7	21	2.4	35/2	71B 4
136	10.1	25	2.0	35/2	71B 4
131	10.5	25.5	3.5	41/2	71B 4
118	11.7	28	1.8	35/2	71B 4
114	12.1	29.4	3.2	41/2	71B 4
106	13.0	31.6	3.2	41/2	71B 4
101	13.6	33	1.5	35/2	71B 4
90	15.3	37.2	2.8	41/2	71B 4
88	15.7	38	1.4	35/2	71B 4
82	16.9	41.1	3.9	45/2	71B 4
76	18.1	44	1.2	35/2	71B 4
75	18.3	44.5	2.4	41/2	71B 4
74	18.7	45.5	3.8	45/2	71B 4
68	20.2	49.1	2.1	41/2	71B 4
65	21.3	52	1.1	35/2	71B 4
64	21.5	52.3	3.4	45/2	71B 4
58	23.8	58	3.5	50/2	71B 4
58	23.9	58.1	1.8	41/2	71B 4
55	25.2	61	0.9	35/2	71B 4
53	25.9	63	3.2	50/2	71B 4
52	26.6	64.7	2.5	45/2	71B 4
48	28.6	69.6	1.5	41/2	71B 4
48	28.5	68	3.2	50/3	71B 4
48	28.7	70	0.9	35/2	71B 4
46	29.8	72	2.8	50/2	71B 4
46	30.2	73.5	2.2	45/2	71B 4
43	32.4	77	2.8	50/3	71B 4
39	35.6	85	2.5	50/3	71B 4
37	37.2	90.5	1.2	41/2	71B 4
37	37.3	90.7	1.9	45/2	71B 4
34	40.5	96	2.2	50/3	71B 4
33	41.4	98.6	2.0	45/3	71B 4
31	44.6	106.2	1.7	45/3	71B 4
30	45.9	111.7	1.5	45/2	71B 4
30	46.2	110	2.0	50/3	71B 4
28	49.6	120.7	0.9	41/2	71B 4
27	50.8	121	1.8	50/3	71B 4



1.7 Performances motoréducteurs

1.7 Prestaciones motorreductores

1.7 Desempenhos motorreductores

n_2 min ⁻¹	ir	T2 Nm	FS'	AM AC	
----------------------------	----	----------	-----	----------	--

0.37 kW	$n_1 = 2790 \text{ min}^{-1}$	63C 2
	$n_1 = 1380 \text{ min}^{-1}$	71B 4
	$n_1 = 910 \text{ min}^{-1}$	80A 6
	$n_1 = 880 \text{ min}^{-1}$	71C 6

27	51.6	122.9	1.6	45/3	71B 4
25	54.4	129.5	0.8	41/3	71B 4
25	55.2	131	3.5	60/3	71B 4
25	54.3	129	1.7	50/3	71B 4
23	60.3	144	2.9	60/3	71B 4
23	60.6	144.3	1.4	45/3	71B 4
21	65.9	157	1.3	50/3	71B 4
19.3	71.5	170	1.3	50/3	71B 4
19.1	72.4	172.4	1.0	45/3	71B 4
19.0	72.7	173	2.7	60/3	71B 4
17.8	77.5	185	1.2	50/3	71B 4
17.6	78.6	187	2.5	60/3	71B 4
17.3	79.8	190.0	1.1	45/3	71B 4
15.5	89.3	213	1.0	50/3	71B 4
15.3	90.4	215	2.1	60/3	71B 4
15.0	92.0	219.1	0.9	45/3	71B 4
13.8	100.2	239	1.8	60/3	71B 4
13.5	102.1	243	0.9	50/3	71B 4
12.3	112.2	267	1.7	60/3	71B 4
12.3	71.5	267	0.8	50/3	71C 6
10.7	128.8	307	1.5	60/3	71B 4
10.1	90.0	325	3.0	80/3	80A 6
9.7	143.0	341	1.2	60/3	71B 4
8.7	104.8	378	2.6	80/3	80A 6
8.4	164.1	391	1.1	60/3	71B 4
7.8	117.2	423	2.3	80/3	80A 6
7.8	112.2	419	1.1	60/3	71C 6
6.8	134.3	485	2.0	80/3	80A 6
6.8	128.8	481	1.0	60/3	71C 6
6.1	149.3	539	1.8	80/3	80A 6
5.3	171.2	618	1.6	80/3	80A 6

0.55 kW	$n_1 = 2800 \text{ min}^{-1}$	71B 2
	$n_1 = 1380 \text{ min}^{-1}$	71C 4
	$n_1 = 1390 \text{ min}^{-1}$	80A 4
	$n_1 = 910 \text{ min}^{-1}$	80B 6

2333	1.2	2.2	13.7	40/1	71B 2
1867	1.5	2.7	12.8	40/1	71B 2
1647	1.7	3.1	12.9	40/1	71B 2
1556	1.8	3.3	4.4	32/1	71B 2
1333	2.1	3.8	3.9	32/1	71B 2
1150	1.2	4.4	6.8	40/1	71C 4
1120	2.5	4.5	3.5	32/1	71B 2
933	3.0	5.5	3.2	32/1	71B 2
920	1.5	5.5	6.3	40/1	71C 4
812	1.7	6.3	6.4	40/1	71C 4
767	1.8	6.6	3.3	32/1	71C 4
718	3.9	7.1	2.5	32/1	71B 2
657	2.1	7.8	2.9	32/1	71C 4
622	4.5	8.2	2.2	32/1	71B 2
552	2.5	9.2	2.6	32/1	71C 4
528	5.3	10	2.0	32/1	71B 2

n_2 min ⁻¹	ir	T2 Nm	FS'	AM AC	
----------------------------	----	----------	-----	----------	--

0.55 kW	$n_1 = 2800 \text{ min}^{-1}$	71B 2
	$n_1 = 1380 \text{ min}^{-1}$	71C 4
	$n_1 = 1390 \text{ min}^{-1}$	80A 4
	$n_1 = 910 \text{ min}^{-1}$	80B 6

460	3.0	11	2.3	32/1	71C 4
443	6.3	11	3.2	35/2	71B 2
406	3.4	13	2.1	32/1	71C 4
405	3.4	12	2.8	35/2	71C 4
354	3.9	14	1.8	32/1	71C 4
343	4.0	15	2.6	35/2	71C 4
307	4.5	17	1.6	32/1	71C 4
294	4.7	17	2.4	35/2	71C 4
282	4.9	18	2.5	40/1	71C 4
260	5.3	20	1.4	32/1	71C 4
255	5.4	20	2.0	35/2	71C 4
242	5.7	21	1.9	40/1	71C 4
238	5.8	21	3.0	50/1	71C 4
218	6.3	23	1.7	35/2	71C 4
212	6.5	24	0.9	32/1	71C 4
209	6.6	24	2.5	50/1	71C 4
197	7.0	26	1.5	40/1	71C 4
188	7.3	27	1.7	35/2	71C 4
185	7.5	26.9	3.0	41/2	80A 4
184	7.5	27.1	2.9	41/2	71C 4
164	8.5	30.5	2.8	41/2	80A 4
162	8.5	30.7	2.8	41/2	71C 4
159	8.7	31	1.6	35/2	71C 4
136	10.1	37	1.4	35/2	71C 4
131	10.5	38.0	2.4	41/2	71C 4
118	11.7	42	1.2	35/2	71C 4
114	12.1	43.8	3.7	45/2	71C 4
114	12.1	43.8	2.2	41/2	71C 4
106	13.0	47.0	2.2	41/2	71C 4
101	13.6	49	1.0	35/2	71C 4
97	14.2	51.3	3.3	45/2	71C 4
95	14.6	53	3.4	50/2	71C 4
90	15.3	55.3	1.9	41/2	71C 4
88	15.7	57	1.0	35/2	71C 4
82	16.8	61	3.1	50/2	71C 4
82	16.9	61.1	2.6	45/2	71C 4
76	18.2	66	2.8	50/2	71C 4
76	18.1	66	0.8	35/2	71C 4
75	18.3	66.2	1.6	41/2	71C 4
74	18.7	67.6	2.6	45/2	71C 4
68	20.2	73.0	1.4	41/2	71C 4
66	20.8	75	2.5	50/2	71C 4
64	21.5	77.7	2.3	45/2	71C 4
58	23.8	86	2.4	50/2	71C 4
58	23.9	86.4	1.2	41/2	71C 4
54	51.6	90.0	2.0	45/3	71B 2
53	25.9	94	2.1	50/2	71C 4
52	26.6	96.2	1.7	45/2	71C 4
48	28.6	103.4	1.0	41/2	71C 4
48	28.5	101	2.1	50/3	71C 4
46	29.8	108	1.9	50/2	71C 4
46	30.2	109.2	1.5	45/2	71C 4
43	32.3	117	3.5	60/2	71C 4
43	32.4	115	1.9	50/3	71C 4

n_2 min ⁻¹	ir	T2 Nm	FS'	AM AC	
----------------------------	----	----------	-----	----------	--

0.55 kW	$n_1 = 2800 \text{ min}^{-1}$	71B 2
	$n_1 = 1380 \text{ min}^{-1}$	71C 4
	$n_1 = 1390 \text{ min}^{-1}$	80A 4
	$n_1 = 910 \text{ min}^{-1}$	80B 6

39	35.7	126	3.3	60/3	71C 4
39	35.6	126	1.7	50/3	71C 4
37	37.3	134.9	1.3	45/2	71C 4
34	40.3	143	2.9	60/3	71C 4
34	40.5	143	1.5	50/3	71C 4
33	41.4	146.5	1.4	45/3	71C 4
31	45.1	160	2.9	60/3	71C 4
31	44.6	157.9	1.1	45/3	71C 4
30	45.9	166.0	1.0	45/2	71C 4
30	46.2	164	1.3	50/3	71C 4
27	51.0	181	2.5	60/3	71C 4
27	50.8	180	1.2	50/3	71C 4
27	51.6	182.6	1.1	45/3	71C 4
25	55.2	195	2.4	60/3	71C 4
25	54.3	192	1.1	50/3	71C 4
23	60.3	213	2.0	60/3	71C 4
23	60.6	214.5	0.9	45/3	71C 4
21	65.9	233	0.9	50/3	71C 4
19.3	71.5	253	0.9	50/3	71C 4
19.0	72.7	257	1.8	60/3	71C 4
17.6	78.6	278	1.7	60/3	71C 4
16.9	82.2	289	3.3	80/3	80A 4
15.3	90.4	320	1.4	60/3	71C 4
13.8	100.2	355	1.2	60/3	71C 4
13.3	104.8	368	2.6	80/3	80A 4
12.3	112.2	397	1.2	60/3	71C 4
11.9	117.2	412	2.3	80/3	80A 4
10.7	128.8	456	1.0	60/3	71C 4
10.3	134.3	472	2.0	80/3	80A 4
9.7	143.0	506	0.8	60/3	71C 4
9.3	149.3	525	1.8	80/3	80A 4
8.1	171.2	602	1.6	80/3	80A 4
6.8	134.3	721	1.3	80/3	80B 6
5.3	171.2	919	1.1	80/3	80B 6

0.75 kW	$n_1 = 2800 \text{ min}^{-1}$	71C 2
	$n_1 = 1390 \text{ min}^{-1}$	80B 4
	$n_1 = 920 \text{ min}^{-1}$	90S 6
	$n_1 = 910 \text{ min}^{-1}$	80C 6

2333	1.2	3.0	10.1	40/1	71C 2
1867	1.5	3.7	9.4	40/1	71C 2
1647	1.7	4.2	9.5	40/1	71C 2
1556	1.8	4.5	3.2	32/1	71C 2
1400	2.0	5.0	9.1	40/1	71C 2
1333	2.1	5.2	2.9	32/1	71C 2
1158	1.2	6.0	5.0	40/1	80B 4
1120	2.5	6.2	2.6	32/1	71C 2
933	3.0	7.4	2.3	32/1	71C 2
927	1.5	7.5	4.7	40/1	80B 4
824	3.4	8.4	2.1	32/1	71C 2
772	1.8	9.0	2.4	32/1	80B 4
662	2.1	10	2.2	32/1	80B 4
556	2.5	12	1.9	32/1	80B 4



1.7 Performances motoréducteurs

1.7 Prestaciones motorreductores

1.7 Desempenhos motorreductores

n_2 min ⁻¹	ir	T2 Nm	FS'	AM AC	
----------------------------	----	----------	-----	----------	--

0.75 kW	$n_1=2800\text{ min}^{-1}$	71C 2
	$n_1=1390\text{ min}^{-1}$	80B 4
	$n_1=920\text{ min}^{-1}$	90S 6
	$n_1=910\text{ min}^{-1}$	80C 6

535	1.7	13	3.1	40/1	80C 6
463	3.0	15	1.7	32/1	80B 4
455	2.0	15	2.9	40/1	80C 6
434	3.2	16	3.1	40/1	80B 4
409	3.4	17	1.5	32/1	80B 4
408	3.4	17	2.1	35/2	80B 4
376	3.7	18	2.7	40/1	80B 4
356	3.9	19	1.3	32/1	80B 4
350	2.6	20	2.5	40/1	80C 6
346	4.0	20	1.9	35/2	80B 4
309	4.5	22	1.2	32/1	80B 4
296	4.7	23	1.7	35/2	80B 4
284	4.9	24	1.8	40/1	80B 4
273	5.1	25	2.9	50/1	80B 4
262	5.3	26	1.0	32/1	80B 4
257	5.4	27	1.5	35/2	80B 4
244	5.7	28	1.4	40/1	80B 4
240	5.8	29	2.2	50/1	80B 4
220	6.3	31	1.3	35/2	80B 4
211	6.6	33	1.8	50/1	80B 4
199	7.0	35	1.1	40/1	80B 4
189	7.3	36	1.3	35/2	80B 4
188	7.4	36.2	3.6	45/2	80B 4
185	7.5	36.7	2.2	41/2	80B 4
178	5.1	39	1.9	50/1	80C 6
164	8.5	41.6	3.4	45/2	80B 4
164	8.5	41.6	2.0	41/2	80B 4
160	8.7	42	1.2	35/2	80B 4
143	9.7	47.5	3.2	45/2	80B 4
137	10.1	50	1.0	35/2	80B 4
134	10.4	51	3.4	50/2	80B 4
132	10.5	51.4	1.8	41/2	80B 4
119	11.7	57	0.9	35/2	80B 4
115	12.1	59.2	2.7	45/2	80B 4
115	12.1	59.2	1.6	41/2	80B 4
111	12.5	61	2.9	50/2	80B 4
107	13.0	63.6	1.6	41/2	80B 4
98	14.2	69.5	2.4	45/2	80B 4
95	14.6	71	2.5	50/2	80B 4
91	15.3	74.9	1.4	41/2	80B 4
83	16.8	82	2.3	50/2	80B 4
82	16.9	82.7	1.9	45/2	80B 4
76	18.2	89	2.1	50/2	80B 4
76	18.3	89.6	1.2	41/2	80B 4
74	18.7	91.5	1.9	45/2	80B 4
69	20.2	98.9	1.1	41/2	80B 4
67	20.8	102	1.9	50/2	80B 4
65	21.5	105.2	1.7	45/2	80B 4
58	23.9	117.0	0.9	41/2	80B 4
58	23.8	117	1.7	50/2	80B 4
54	25.9	127	1.6	50/2	80B 4
52	26.6	130.2	1.2	45/2	80B 4
49	28.1	138	3.0	60/2	80B 4
49	28.5	137	1.6	50/3	80B 4

n_2 min ⁻¹	ir	T2 Nm	FS'	AM AC	
----------------------------	----	----------	-----	----------	--

0.75 kW	$n_1=2800\text{ min}^{-1}$	71C 2
	$n_1=1390\text{ min}^{-1}$	80B 4
	$n_1=920\text{ min}^{-1}$	90S 6
	$n_1=910\text{ min}^{-1}$	80C 6

47	29.8	146	1.4	50/2	80B 4
46	30.2	147.8	1.1	45/2	80B 4
44	31.6	151	3.0	60/3	80B 4
43	32.3	158	2.6	60/2	80B 4
43	32.4	155	1.4	50/3	80B 4
39	35.7	171	2.5	60/3	80B 4
39	35.6	171	1.2	50/3	80B 4
37	37.3	182.6	0.9	45/2	80B 4
34	40.3	193	2.2	60/3	80B 4
34	40.5	194	1.1	50/3	80B 4
34	41.4	198.4	1.0	45/3	80B 4
31	44.6	213.7	0.8	45/3	80B 4
31	45.1	216	2.1	60/3	80B 4
30	46.2	221	1.0	50/3	80B 4
27	51.0	244	1.9	60/3	80B 4
27	50.8	243	0.9	50/3	80B 4
27	51.6	247.3	0.8	45/3	80B 4
26	54.3	260	0.8	50/3	80B 4
25	55.2	265	1.7	60/3	80B 4
23	60.3	289	1.5	60/3	80B 4
21	65.7	315	3.1	80/3	80B 4
19.1	72.7	348	1.3	60/3	80B 4
18.3	76.0	364	2.7	80/3	80B 4
17.7	78.6	377	1.2	60/3	80B 4
16.9	82.2	394	2.5	80/3	80B 4
15.4	90.0	431	2.2	80/3	80B 4
15.4	90.4	433	1.1	60/3	80B 4
13.9	100.2	480	0.9	60/3	80B 4
13.3	104.8	502	1.9	80/3	80B 4
12.4	112.2	538	0.9	60/3	80B 4
11.9	117.2	562	1.7	80/3	80B 4
10.3	134.3	644	1.5	80/3	80B 4
9.3	149.3	715	1.4	80/3	80B 4
8.1	171.2	820	1.2	80/3	80B 4
7.8	117.2	858	1.1	80/3	80C 6
6.8	134.3	983	1.0	80/3	80C 6
6.1	149.3	1093	0.9	80/3	80C 6
5.1	182.0	1318	2.5	120/3	90S 6
4.1	222.0	1607	2.1	120/3	90S 6
3.3	277.3	2008	1.6	120/3	90S 6

0.88 kW	$n_1=1350\text{ min}^{-1}$	80C 4
----------------	----------------------------	-------

1125	1.2	7.2	4.1	40/1	80C 4
900	1.5	9.1	3.9	40/1	80C 4
794	1.7	10	3.9	40/1	80C 4
750	1.8	11	2.0	32/1	80C 4
675	2.0	12	3.7	40/1	80C 4
643	2.1	13	1.8	32/1	80C 4
540	2.5	15	1.6	32/1	80C 4

n_2 min ⁻¹	ir	T2 Nm	FS'	AM AC	
----------------------------	----	----------	-----	----------	--

0.88 kW	$n_1=1350\text{ min}^{-1}$	80C 4
----------------	----------------------------	-------

519	2.6	16	3.2	40/1	80C 4
450	3.0	18	1.4	32/1	80C 4
422	3.2	19	2.6	40/1	80C 4
397	3.4	21	1.3	32/1	80C 4
396	3.4	20.2	1.7	35/2	80C 4
365	3.7	22	2.2	40/1	80C 4
346	3.9	24	1.1	32/1	80C 4
336	4.0	23.8	1.6	35/2	80C 4
300	4.5	27	1.0	32/1	80C 4
287	4.7	27.8	1.4	35/2	80C 4
276	4.9	30	1.5	40/1	80C 4
265	5.1	31	2.4	50/1	80C 4
255	5.3	32	0.8	32/1	80C 4
249	5.4	32	1.2	35/2	80C 4
237	5.7	34	1.2	40/1	80C 4
233	5.8	35	1.9	50/1	80C 4
233	5.8	34.3	3.4	45/2	80C 4
213	6.3	37.4	1.1	35/2	80C 4
211	6.4	37.8	3.2	45/2	80C 4
205	6.6	40	1.5	50/1	80C 4
199	6.8	41	3.0	60/1	80C 4
193	7.0	42	0.9	40/1	80C 4
184	7.3	43.4	1.0	35/2	80C 4
182	7.4	43.8	3.0	45/2	80C 4
180	7.5	44.4	1.8	41/2	80C 4
163	8.3	49	3.2	50/2	80C 4
159	8.5	50.3	2.8	45/2	80C 4
159	8.5	50.3	1.7	41/2	80C 4
156	8.7	51.3	1.0	35/2	80C 4
147	9.2	54	3.0	50/2	80C 4
139	9.7	57.4	2.6	45/2	80C 4
133	10.1	59.9	0.8	35/2	80C 4
130	10.4	62	2.8	50/2	80C 4
129	10.5	62.1	1.4	41/2	80C 4
112	12.1	71.6	2.2	45/2	80C 4
112	12.1	71.6	1.3	41/2	80C 4
108	12.5	74	2.4	50/2	80C 4
104	13.0	76.9	1.3	41/2	80C 4
95	14.2	84.0	2.0	45/2	80C 4
92	14.6	86	2.1	50/2	80C 4
88	15.3	90.5	1.2	41/2	80C 4
80	16.8	99	1.9	50/2	80C 4
80	16.9	99.9	1.6	45/2	80C 4
74	18.3	108	3.5	60/2	80C 4
74	18.2	108	1.7	50/2	80C 4
74	18.3	108.2	1.0	41/2	80C 4
72	18.7	110.6	1.6	45/2	80C 4
69	19.7	117	3.3	60/2	80C 4
67	20.2	119.5	0.9	41/2	80C 4
65	20.8	123	1.5	50/2	80C 4
63	21.5	127.1	1.4	45/2	80C 4
61	22.1	131	3.3	60/2	80C 4
57	23.8	141	1.4	50/2	80C 4
53	25.3	150	3.0	60/2	80C 4



1.7 Performances motoréducteurs

1.7 Prestaciones motorreductores

1.7 Desempenhos motorreductores

n_2 min ⁻¹	ir	T2 Nm	FS'	AM AC	
----------------------------	----	----------	-----	----------	--

0.88 kW		$n_1 = 1350 \text{ min}^{-1}$	80C 4
----------------	--	-------------------------------	-------

52	25.9	153	1.3	50/2	80C 4
51	26.6	157.3	1.0	45/2	80C 4
48	28.0	162	2.8	60/3	80C 4
48	28.1	166	2.5	60/2	80C 4
47	28.5	165	1.3	50/3	80C 4
45	29.8	176	1.1	50/2	80C 4
45	30.2	178.6	0.9	45/2	80C 4
43	31.6	183	2.5	60/3	80C 4
42	32.3	191	2.1	60/2	80C 4
42	32.4	188	1.2	50/3	80C 4
38	35.7	207	2.0	60/3	80C 4
38	35.6	206	1.0	50/3	80C 4
33	40.3	233	1.8	60/3	80C 4
33	40.5	234	0.9	50/3	80C 4
33	41.4	239.7	0.8	45/3	80C 4
30	45.1	261	1.8	60/3	80C 4
29	46.2	267	0.8	50/3	80C 4
27	50.9	295	3.3	80/3	80C 4
26	51.0	295	1.6	60/3	80C 4
25	55.1	319	3.0	80/3	80C 4
24	55.2	320	1.4	60/3	80C 4
22	60.3	349	1.2	60/3	80C 4
21	65.7	380	2.5	80/3	80C 4
18.6	72.7	421	1.1	60/3	80C 4
17.8	76.0	440	2.2	80/3	80C 4
17.2	78.6	455	1.0	60/3	80C 4
16.4	82.2	476	2.0	80/3	80C 4
15.0	90.0	521	1.9	80/3	80C 4
14.9	90.4	523	0.9	60/3	80C 4
12.9	104.8	607	1.6	80/3	80C 4
11.5	117.2	679	1.4	80/3	80C 4
10.1	134.3	778	1.2	80/3	80C 4
9.0	149.3	864	1.1	80/3	80C 4
7.9	171.2	991	1.0	80/3	80C 4

1.1 kW		$n_1 = 2830 \text{ min}^{-1}$	80B 2
		$n_1 = 1390 \text{ min}^{-1}$	80D 4
		$n_1 = 1400 \text{ min}^{-1}$	90S 4
		$n_1 = 920 \text{ min}^{-1}$	90L 6

2358	1.2	4.3	6.9	40/1	80B 2
1887	1.5	5.4	6.5	40/1	80B 2
1665	1.7	6.1	6.5	40/1	80B 2
1572	1.8	6.5	2.2	32/1	80B 2
1415	2.0	7.2	6.2	40/1	80B 2
1348	2.1	7.6	2.0	32/1	80B 2
1286	2.2	7.9	6.3	40/1	80B 2
1158	1.2	8.8	3.4	40/1	80D 4
943	3.0	11	1.6	32/1	80B 2
927	1.5	11	3.2	40/1	80D 4
818	1.7	12	3.2	40/1	80D 4
772	1.8	13	1.6	32/1	80D 4
767	1.2	13	2.3	40/1	90L 6
726	3.9	14	1.3	32/1	80B 2

n_2 min ⁻¹	ir	T2 Nm	FS'	AM AC	
----------------------------	----	----------	-----	----------	--

1.1 kW		$n_1 = 2830 \text{ min}^{-1}$	80B 2
		$n_1 = 1390 \text{ min}^{-1}$	80D 4
		$n_1 = 1400 \text{ min}^{-1}$	90S 4
		$n_1 = 920 \text{ min}^{-1}$	90L 6

695	2.0	15	3.1	40/1	80D 4
662	2.1	15	1.5	32/1	80D 4
632	2.2	16	3.1	40/1	80D 4
556	2.5	18	1.3	32/1	80D 4
535	2.6	19	2.6	40/1	80D 4
463	3.0	22	1.1	32/1	80D 4
460	2.0	22	2.0	40/1	90L 6
434	3.2	23	2.1	40/1	80D 4
418	2.2	24	2.1	40/1	90L 6
409	3.4	25	1.0	32/1	80D 4
408	3.4	24	1.4	35/2	80D 4
386	3.6	26	3.4	50/1	80D 4
376	3.7	27	1.8	40/1	80D 4
356	3.9	29	3.1	50/1	80D 4
356	3.9	29	0.9	32/1	80D 4
346	4.0	29	1.3	35/2	80D 4
309	4.5	33	0.8	32/1	80D 4
296	4.7	34	1.2	35/2	80D 4
284	4.9	36	1.3	40/1	80D 4
273	5.1	37	2.0	50/1	80D 4
257	5.4	39	1.0	35/2	80D 4
244	5.7	42	1.0	40/1	80D 4
240	5.8	43	1.5	50/1	80D 4
240	5.8	41.6	2.8	45/2	80D 4
236	5.9	43	3.4	60/1	80D 4
221	6.3	45	3.2	50/2	80D 4
220	6.3	45	0.9	35/2	80D 4
217	6.4	45.9	2.6	45/2	80D 4
211	6.6	48	1.2	50/1	80D 4
189	7.3	53	0.9	35/2	80D 4
188	7.4	53	2.9	50/2	80D 4
188	7.4	53.1	2.4	45/2	80D 4
185	7.5	53.8	1.5	41/2	80D 4
167	8.3	60	2.7	50/2	80D 4
164	8.5	61.0	2.3	45/2	80D 4
164	8.5	61.0	1.4	41/2	80D 4
160	8.7	62	0.8	35/2	80D 4
151	9.2	66	2.5	50/2	80D 4
134	10.4	75	2.3	50/2	80D 4
132	10.5	75.4	1.2	41/2	80D 4
115	12.1	86.9	1.8	45/2	80D 4
115	12.1	86.9	1.1	41/2	80D 4
111	12.5	90	1.9	50/2	80D 4
107	13.0	93.3	1.1	41/2	80D 4
98	14.2	102.0	1.7	45/2	80D 4
95	14.6	105	1.7	50/2	80D 4
91	15.3	109.8	1.0	41/2	80D 4
83	16.8	121	1.6	50/2	80D 4
82	16.9	121.3	1.3	45/2	80D 4
76	18.3	131	2.9	60/2	80D 4
76	18.2	131	1.4	50/2	80D 4
76	18.3	131.4	0.8	41/2	80D 4
74	18.7	134.3	1.3	45/2	80D 4
71	19.7	141	2.7	60/2	80D 4

n_2 min ⁻¹	ir	T2 Nm	FS'	AM AC	
----------------------------	----	----------	-----	----------	--

1.1 kW		$n_1 = 2830 \text{ min}^{-1}$	80B 2
		$n_1 = 1390 \text{ min}^{-1}$	80D 4
		$n_1 = 1400 \text{ min}^{-1}$	90S 4
		$n_1 = 920 \text{ min}^{-1}$	90L 6

67	20.8	149	1.3	50/2	80D 4
65	21.5	154.4	1.2	45/2	80D 4
63	22.1	159	2.7	60/2	80D 4
58	23.8	171	1.2	50/2	80D 4
55	25.3	182	2.5	60/2	80D 4
54	25.9	186	1.1	50/2	80D 4
49	28.1	202	2.0	60/2	80D 4
47	29.8	214	0.9	50/2	80D 4
43	32.3	232	1.8	60/2	80D 4
43	32.4	228	0.9	50/3	80D 4
39	35.7	251	1.7	60/3	80D 4
39	35.6	250	0.8	50/3	80D 4
39	23.8	258	0.8	50/2	90L 6
34	40.3	283	3.4	80/3	80D 4
34	40.3	283	1.5	60/3	80D 4
33	28.1	305	1.3	60/2	90L 6
32	44.0	309	3.1	80/3	80D 4
31	45.1	317	1.5	60/3	80D 4
27	50.9	358	2.7	80/3	80D 4
27	51.0	358	1.3	60/3	80D 4
25	55.1	387	2.5	80/3	80D 4
25	55.2	388	1.2	60/3	80D 4
23	60.3	424	1.0	60/3	80D 4
21	65.7	462	2.1	80/3	80D 4
19.1	72.7	511	0.9	60/3	80D 4
18.3	76.0	534	1.8	80/3	80D 4
17.7	78.6	552	0.8	60/3	80D 4
16.9	82.2	578	1.7	80/3	80D 4
15.4	90.0	633	1.5	80/3	80D 4
15.2	91.9	641	3.1	100/3	90S 4
13.3	104.8	737	1.3	80/3	80D 4
11.9	117.8	822	2.4	100/3	90S 4
11.9	117.2	824	1.2	80/3	80D 4
10.8	129.5	904	2.2	100/3	90S 4
10.3	134.3	944	1.0	80/3	80D 4
9.8	142.9	997	3.3	120/3	90S 4
9.5	147.2	1027	1.9	100/3	90S 4
9.4	149.3	1042	0.9	80/3	90S 4
9.3	149.3	1049	0.9	80/3	80D 4
8.7	161.8	1129	1.8	100/3	90S 4
8.1	171.2	1203	0.8	80/3	80D 4
8.0	175.7	1226	2.7	120/3	90S 4
7.1	197.1	1375	2.4	120/3	90S 4
7.1	129.5	1375	1.4	100/3	90L 6
6.3	222.0	1549	2.1	120/3	90S 4
6.3	147.2	1563	1.3	100/3	90L 6
5.0	277.3	1935	1.7	120/3	90S 4
4.1	222.0	2357	1.4	120/3	90L 6
3.3	277.3	2945	1.1	120/3	90L 6



1.7 Performances motoréducteurs

1.7 Prestaciones motorreductores

1.7 Desempenhos motorreductores

n_2 min ⁻¹	ir	T2 Nm	FS'	AM AC	
----------------------------	----	----------	-----	----------	--

1.5 kW	$n_1=2830 \text{ min}^{-1}$	80C 2
	$n_1=1400 \text{ min}^{-1}$	90L 4
	$n_1=940 \text{ min}^{-1}$	100A 6
	$n_1=925 \text{ min}^{-1}$	90LB 6

2358	1.2	6.0	5.1	40/1	80C 2
1887	1.5	7.0	4.8	40/1	80C 2
1665	1.7	8.0	4.8	40/1	80C 2
1572	1.8	9.0	1.6	32/1	80C 2
1167	1.2	12	2.5	40/1	90L 4
1132	2.5	12	1.3	32/1	80C 2
943	3.0	15	1.2	32/1	80C 2
933	1.5	15	2.4	40/1	90L 4
884	3.2	16	3.2	40/1	80C 2
824	1.7	17	2.4	40/1	90L 4
783	1.2	18	1.7	40/1	100A 6
765	3.7	18	2.8	40/1	80C 2
700	2.0	20	2.3	40/1	90L 4
636	2.2	22	2.3	40/1	90L 4
578	4.9	24	1.9	40/1	80C 2
560	2.5	25	3.2	50/1	90L 4
538	2.6	26	1.9	40/1	90L 4
500	2.8	28	3.1	50/1	90L 4
452	3.1	31	2.9	50/1	90L 4
438	3.2	32	1.6	40/1	90L 4
424	3.3	33	2.7	50/1	90L 4
389	3.6	36	2.5	50/1	90L 4
378	3.7	37	1.4	40/1	90L 4
359	3.9	39	2.3	50/1	90L 4
286	4.9	49	0.9	40/1	90L 4
275	5.1	51	1.5	50/1	90L 4
269	5.2	52	3.2	60/1	90L 4
241	5.8	56.4	2.0	45/2	90L 4
241	5.8	58	1.1	50/1	90L 4
237	5.9	59	2.5	60/1	90L 4
222	6.3	61	2.4	50/2	90L 4
219	6.4	62.2	1.9	45/2	90L 4
212	6.6	66	0.9	50/1	90L 4
206	6.8	67	1.9	60/1	90L 4
189	7.4	71.9	1.8	45/2	90L 4
189	7.4	72	2.1	50/2	90L 4
187	7.5	72.9	1.1	41/2	90L 4
169	8.3	81	2.0	50/2	90L 4
165	8.5	82.6	1.7	45/2	90L 4
165	8.5	82.6	1.0	41/2	90L 4
152	9.2	89	1.8	50/2	90L 4
144	9.7	94.3	1.6	45/2	90L 4
135	10.4	101	1.7	50/2	90L 4
133	10.5	102.1	0.9	41/2	90L 4
124	11.3	110	3.3	60/2	90L 4
116	12.1	117.6	1.4	45/2	90L 4
116	12.1	117.6	0.8	41/2	90L 4
113	12.4	121	3.1	60/2	90L 4
112	12.5	122	1.4	50/2	90L 4
108	13.0	126.4	0.8	41/2	90L 4
99	14.2	138.0	1.2	45/2	90L 4
98	14.3	139	2.8	60/2	90L 4
96	14.6	142	1.3	50/2	90L 4
90	15.5	151	2.7	60/2	90L 4

n_2 min ⁻¹	ir	T2 Nm	FS'	AM AC	
----------------------------	----	----------	-----	----------	--

1.5 kW	$n_1=2830 \text{ min}^{-1}$	80C 2
	$n_1=1400 \text{ min}^{-1}$	90L 4
	$n_1=940 \text{ min}^{-1}$	100A 6
	$n_1=925 \text{ min}^{-1}$	90LB 6

83	16.8	163	1.2	50/2	90L 4
83	16.9	164.3	1.0	45/2	90L 4
77	18.3	178	2.1	60/2	90L 4
77	18.2	177	1.0	50/2	90L 4
75	18.7	181.8	1.0	45/2	90L 4
71	19.7	191	2.0	60/2	90L 4
67	20.8	202	0.9	50/2	90L 4
65	21.5	209.0	0.9	45/2	90L 4
63	22.1	215	2.0	60/2	90L 4
59	23.8	231	0.9	50/2	90L 4
55	25.3	246	1.8	60/2	90L 4
50	28.1	273	1.5	60/2	90L 4
48	28.9	281	3.3	80/2	90L 4
44	31.8	309	3.0	80/2	90L 4
43	32.3	314	1.3	60/2	90L 4
39	35.7	340	2.8	80/3	90L 4
39	35.7	340	1.2	60/3	90L 4
35	40.3	383	2.5	80/3	90L 4
35	40.3	383	1.1	60/3	90L 4
32	44.0	419	2.3	80/3	90L 4
31	45.1	429	1.1	60/3	90L 4
28	50.9	484	2.0	80/3	90L 4
27	51.0	485	0.9	60/3	90L 4
25	55.1	524	1.8	80/3	90L 4
25	55.2	525	0.9	60/3	90L 4
22	64.5	614	3.2	100/3	90L 4
21	65.7	625	1.5	80/3	90L 4
19.0	73.6	700	2.8	100/3	90L 4
18.4	76.0	723	1.3	80/3	90L 4
17.7	78.9	751	2.6	100/3	90L 4
17.0	82.2	782	1.2	80/3	90L 4
15.6	90.0	856	1.1	80/3	90L 4
15.2	91.9	875	2.3	100/3	90L 4
14.2	98.6	938	2.1	100/3	90L 4
13.6	102.6	976	3.4	120/3	90L 4
13.4	104.8	997	1.0	80/3	90L 4
12.2	114.4	1089	3.0	120/3	90L 4
11.9	117.8	1121	1.8	100/3	90L 4
11.9	117.2	1115	0.9	80/3	90L 4
11.2	124.9	1189	2.8	120/3	90L 4
10.8	129.5	1232	1.6	100/3	90L 4
9.8	142.9	1360	2.4	120/3	90L 4
9.5	147.2	1401	1.4	100/3	90L 4
9.4	98.6	1420	1.4	100/3	90LB 6
9.0	156.0	1484	2.2	120/3	90L 4
8.7	161.8	1540	1.3	100/3	90L 4
8.0	175.7	1672	2.0	120/3	90L 4
7.9	117.8	1697	1.2	100/3	90LB 6
7.7	182.0	1732	1.9	120/3	90L 4
7.1	197.1	1876	1.8	120/3	90L 4
7.1	129.5	1865	1.1	100/3	90LB 6
6.8	205.0	1951	1.7	120/3	90L 4
6.4	147.2	2086	1.0	100/3	100A 6
6.3	222.0	2113	1.6	120/3	90L 4

n_2 min ⁻¹	ir	T2 Nm	FS'	AM AC	
----------------------------	----	----------	-----	----------	--

1.5 kW	$n_1=2830 \text{ min}^{-1}$	80C 2
	$n_1=1400 \text{ min}^{-1}$	90L 4
	$n_1=940 \text{ min}^{-1}$	100A 6
	$n_1=925 \text{ min}^{-1}$	90LB 6

5.7	161.8	2330	0.9	100/3	90LB 6
5.0	277.3	2639	1.3	120/3	90L 4
4.2	222.0	3197	1.0	120/3	90LB 6
3.3	277.3	3994	0.8	120/3	90LB 6

1.8 kW	$n_1=2770 \text{ min}^{-1}$	80D 2
	$n_1=1400 \text{ min}^{-1}$	90L 4
	$n_1=940 \text{ min}^{-1}$	100B 6

2308	1.2	7.0	4.2	40/1	80D 2
1847	1.5	9.0	3.9	40/1	80D 2
1629	1.7	10	3.9	40/1	80D 2
1539	1.8	11	1.3	32/1	80D 2
1167	1.2	14	2.1	40/1	90L 4
1077	1.3	15	3.6	50/1	90LB 4
933	1.5	18	3.5	50/1	90LB 4
933	1.5	18	2.0	40/1	90LB 4
824	1.7	20	2.0	40/1	90LB 4
749	3.7	22	2.2	40/1	80D 2
700	2.0	24	3.4	50/1	90LB 4
700	2.0	24	1.9	40/1	90LB 4
636	2.2	26	1.9	40/1	90LB 4
627	1.5	27	2.4	50/1	100B 6
560	2.5	30	2.7	50/1	90LB 4
538	2.6	31	1.6	40/1	90LB 4
500	2.8	33	2.5	50/1	90LB 4
452	3.1	37	2.4	50/1	90LB 4
438	3.2	38	1.3	40/1	90LB 4
424	3.3	39	2.3	50/1	90LB 4
389	3.6	43	2.1	50/1	90LB 4
378	3.7	44	1.1	40/1	90LB 4
359	3.9	46	1.9	50/1	90LB 4
298	4.7	56	3.0	60/1	90LB 4
275	5.1	61	1.2	50/1	90LB 4
269	5.2	62	2.6	60/1	90LB 4
241	5.8	67.7	1.7	45/2	90LB 4
241	5.8	69	0.9	50/1	90LB 4
237	5.9	70	2.1	60/1	90LB 4
222	6.3	73	2.0	50/2	90LB 4
219	6.4	74.7	1.6	45/2	90LB 4
206	6.8	81	1.5	60/1	90LB 4
189	7.4	86.3	1.5	45/2	90LB 4
189	7.4	86	1.8	50/2	90LB 4
187	7.5	87.5	0.9	41/2	90LB 4
169	8.3	97	1.6	50/2	90LB 4
165	8.5	99.1	1.4	45/2	90LB 4
165	8.5	99.1	0.9	41/2	90LB 4
157	8.9	104	3.4	60/2	90LB 4
144	9.7	113.1	1.3	45/2	90LB 4
139	10.1	118	3.0	60/2	90LB 4
135	10.4	121	1.4	50/2	90LB 4



1.7 Performances motoréducteurs

1.7 Prestaciones motorreductores

1.7 Desempenhos motorreductores

n ₂ min ⁻¹	ir	T2 Nm	FS'	AM AC	
-------------------------------------	----	----------	-----	----------	--

1.8 kW	n ₁ = 2770 min ⁻¹ n ₁ = 1400 min ⁻¹ n ₁ = 940 min ⁻¹	80D 2 90LB 4 100B 6
---------------	--	---------------------------

124	11.3	132	2.8	60/2	90LB 4
116	12.1	141.1	1.1	45/2	90LB 4
113	12.4	145	2.6	60/2	90LB 4
112	12.5	146	1.2	50/2	90LB 4
99	14.2	165.6	1.0	45/2	90LB 4
96	14.6	170	1.1	50/2	90LB 4
90	15.5	181	2.2	60/2	90LB 4
83	16.8	196	1.0	50/2	90LB 4
83	16.9	197.1	0.8	45/2	90LB 4
77	18.3	213	1.8	60/2	90LB 4
77	18.2	212	0.9	50/2	90LB 4
75	18.7	218.1	0.8	45/2	90LB 4
71	19.7	230	1.7	60/2	90LB 4
63	22.1	258	1.7	60/2	90LB 4
62	22.7	265	3.4	80/2	90LB 4
56	24.9	290	3.2	80/2	90LB 4
55	25.3	295	1.5	60/2	90LB 4
50	28.1	328	1.3	60/2	90LB 4
48	28.9	337	2.8	80/2	90LB 4
44	31.8	371	2.5	80/2	90LB 4
43	32.3	377	1.1	60/2	90LB 4
39	35.7	408	2.4	80/3	90LB 4
39	35.7	408	1.0	60/3	90LB 4
35	40.3	460	2.1	80/3	90LB 4
35	40.3	460	0.9	60/3	90LB 4
32	44.0	502	1.9	80/3	90LB 4
31	45.1	515	0.9	60/3	90LB 4
28	50.9	581	1.7	80/3	90LB 4
27	52.8	603	3.3	100/3	90LB 4
25	56.7	647	3.1	100/3	90LB 4
25	55.1	629	1.5	80/3	90LB 4
22	64.5	737	2.7	100/3	90LB 4
21	65.7	750	1.3	80/3	90LB 4
19.0	73.6	840	2.4	100/3	90LB 4
18.4	76.0	868	1.1	80/3	90LB 4
17.7	78.9	901	2.2	100/3	90LB 4
17.0	82.2	939	3.5	120/3	90LB 4
17.0	82.2	939	1.0	80/3	90LB 4
15.6	90.0	1028	0.9	80/3	90LB 4
15.4	90.7	1036	3.2	120/3	90LB 4
15.2	91.9	1049	1.9	100/3	90LB 4
14.2	98.6	1126	1.8	100/3	90LB 4
13.6	102.6	1172	2.8	120/3	90LB 4
13.4	104.8	1197	0.8	80/3	90LB 4
12.2	114.4	1306	2.5	120/3	90LB 4
11.9	117.8	1345	1.5	100/3	90LB 4
11.2	124.9	1426	2.3	120/3	90LB 4
10.8	129.5	1479	1.3	100/3	90LB 4
9.8	142.9	1632	2.0	120/3	90LB 4
9.5	147.2	1681	1.2	100/3	90LB 4
9.0	156.0	1781	1.9	120/3	90LB 4
8.7	161.8	1848	1.1	100/3	90LB 4
8.0	175.7	2006	1.6	120/3	90LB 4
7.7	182.0	2078	1.6	120/3	90LB 4

n ₂ min ⁻¹	ir	T2 Nm	FS'	AM AC	
-------------------------------------	----	----------	-----	----------	--

1.8 kW	n ₁ = 2770 min ⁻¹ n ₁ = 1400 min ⁻¹ n ₁ = 940 min ⁻¹	80D 2 90LB 4 100B 6
---------------	--	---------------------------

7.1	197.1	2251	1.5	120/3	90LB 4
6.8	205.0	2341	1.4	120/3	90LB 4
6.3	222.0	2535	1.3	120/3	90LB 4
5.5	256.0	2923	1.1	120/3	90LB 4
5.0	277.3	3167	1.0	120/3	90LB 4
4.2	222.0	3776	0.9	120/3	100B 6

2.2 kW	n ₁ = 2840 min ⁻¹ n ₁ = 1410 min ⁻¹	90L 2 100A 4
---------------	--	-----------------

2367	1.2	9.0	3.5	40/1	90L 2
1893	1.5	11	3.3	40/1	90L 2
1671	1.7	12	3.3	40/1	90L 2
1420	2.0	14	3.1	40/1	90L 2
1291	2.2	16	3.2	40/1	90L 2
1175	1.2	17	1.7	40/1	100A 4
1085	1.3	19	2.9	50/1	100A 4
940	1.5	22	2.9	50/1	100A 4
940	1.5	22	1.6	40/1	100A 4
829	1.7	25	1.6	40/1	100A 4
783	1.8	26	3.1	50/1	100A 4
705	2.0	29	2.8	50/1	100A 4
705	2.0	29	1.6	40/1	100A 4
641	2.2	32	1.6	40/1	100A 4
564	2.5	36	2.2	50/1	100A 4
542	2.6	38	1.3	40/1	100A 4
504	2.8	40	2.1	50/1	100A 4
455	3.1	45	2.0	50/1	100A 4
441	3.2	46	1.1	40/1	100A 4
427	3.3	48	1.9	50/1	100A 4
415	3.4	49	3.5	60/1	100A 4
392	3.6	52	3.3	60/1	100A 4
392	3.6	52	1.7	50/1	100A 4
381	3.7	53	0.9	40/1	100A 4
362	3.9	56	1.6	50/1	100A 4
300	4.7	68	2.5	60/1	100A 4
276	5.1	74	1.0	50/1	100A 4
271	5.2	75	2.2	60/1	100A 4
243	5.8	82.1	1.4	45/2	100A 4
239	5.9	85	1.7	60/1	100A 4
224	6.3	89	1.6	50/2	100A 4
220	6.4	90.6	1.3	45/2	100A 4
220	6.4	93	3.6	80/1	100A 4
207	6.8	98	1.3	60/1	100A 4
191	7.4	104.8	1.2	45/2	100A 4
178	7.9	112	3.0	60/2	100A 4
170	8.3	117	1.3	50/2	100A 4
166	8.5	120.3	1.2	45/2	100A 4
158	8.9	126	2.8	60/2	100A 4
153	9.2	130	1.3	50/2	100A 4

n ₂ min ⁻¹	ir	T2 Nm	FS'	AM AC	
-------------------------------------	----	----------	-----	----------	--

2.2 kW	n ₁ = 2840 min ⁻¹ n ₁ = 1410 min ⁻¹	90L 2 100A 4
---------------	--	-----------------

145	9.7	137.3	1.1	45/2	100A 4
140	10.1	143	2.5	60/2	100A 4
136	10.4	147	1.2	50/2	100A 4
125	11.3	160	2.3	60/2	100A 4
117	12.1	171.3	0.9	45/2	100A 4
114	12.4	176	2.1	60/2	100A 4
113	12.5	177	1.0	50/2	100A 4
99	14.2	201.0	0.8	45/2	100A 4
99	14.3	202	1.9	60/2	100A 4
97	14.6	207	0.9	50/2	100A 4
91	15.5	219	1.8	60/2	100A 4
78	18.1	256	3.4	80/2	100A 4
77	18.3	259	1.5	60/2	100A 4
73	19.4	275	3.2	80/2	100A 4
72	19.7	279	1.4	60/2	100A 4
64	22.1	313	1.4	60/2	100A 4
62	22.7	321	2.8	80/2	100A 4
57	24.9	352	2.7	80/2	100A 4
56	25.3	358	1.3	60/2	100A 4
50	28.1	398	1.0	60/2	100A 4
49	28.9	409	2.3	80/2	100A 4
44	31.8	450	2.1	80/2	100A 4
44	32.3	457	0.9	60/2	100A 4
39	35.7	495	2.0	80/3	100A 4
39	35.7	495	0.8	60/3	100A 4
35	40.6	563	3.5	100/3	100A 4
35	40.3	558	1.7	80/3	100A 4
32	44.0	610	1.6	80/3	100A 4
31	45.2	626	3.2	100/3	100A 4
28	50.9	705	1.4	80/3	100A 4
27	52.8	732	2.7	100/3	100A 4
26	55.1	764	1.3	80/3	100A 4
25	56.7	786	2.5	100/3	100A 4
22	64.5	894	2.2	100/3	100A 4
21	65.7	910	1.1	80/3	100A 4
19.4	72.6	1006	3.3	120/3	100A 4
19.2	73.6	1020	1.9	100/3	100A 4
18.6	76.0	1053	0.9	80/3	100A 4
18.1	77.7	1077	3.1	120/3	100A 4
17.9	78.9	1093	1.8	100/3	100A 4
17.2	82.2	1139	2.9	120/3	100A 4
17.2	82.2	1139	0.8	80/3	100A 4
15.5	90.7	1257	2.6	120/3	100A 4
15.3	91.9	1274	1.6	100/3	100A 4
14.3	98.6	1366	1.5	100/3	100A 4
13.7	102.6	1422	2.3	120/3	100A 4
12.3	114.4	1585	2.1	120/3	100A 4
12.0	117.8	1632	1.2	100/3	100A 4
11.3	124.9	1731	1.9	120/3	100A 4
10.9	129.5	1795	1.1	100/3	100A 4
9.9	142.9	1980	1.7	120/3	100A 4
9.6	147.2	2040	1.0	100/3	100A 4
9.0	156.0	2162	1.5	120/3	100A 4
8.7	161.8	2242	0.9	100/3	100A 4



1.7 Performances motoréducteurs

1.7 Prestaciones motorreductores

1.7 Desempenhos motorreductores

n_2 min ⁻¹	ir	T2 Nm	FS'	AM AC	
----------------------------	----	----------	-----	----------	---

2.2 kW	$n_1=2840 \text{ min}^{-1}$ $n_1=1410 \text{ min}^{-1}$	90L 2 100A 4
---------------	--	-----------------

8.0	175.7	2435	1.4	120/3	100A 4
7.7	182.0	2522	1.3	120/3	100A 4
7.2	197.1	2731	1.2	120/3	100A 4
6.9	205.0	2841	1.2	120/3	100A 4
6.4	222.0	3076	1.1	120/3	100A 4
5.5	256.0	3548	0.9	120/3	100A 4
5.1	277.3	3843	0.9	120/3	100A 4

3 kW	$n_1=2840 \text{ min}^{-1}$ $n_1=1420 \text{ min}^{-1}$	90LB 2 100B 4
-------------	--	------------------

2367	1.2	12	2.6	40/1	90LB 2
1893	1.5	15	2.4	40/1	90LB 2
1671	1.7	17	2.4	40/1	90LB 2
1420	2.0	20	2.3	40/1	90LB 2
1291	2.2	22	2.3	40/1	90LB 2
1183	1.2	23	1.3	40/1	100B 4
1092	1.3	25	2.2	50/1	100B 4
947	1.5	29	2.1	50/1	100B 4
947	1.5	29	1.2	40/1	100B 4
835	1.7	33	1.2	40/1	100B 4
789	1.8	35	2.3	50/1	100B 4
710	2.0	39	2.0	50/1	100B 4
710	2.0	39	1.1	40/1	100B 4
645	2.2	43	1.2	40/1	100B 4
568	2.5	49	1.6	50/1	100B 4
546	2.6	51	1.0	40/1	100B 4
526	2.7	53	3.2	60/1	100B 4
507	2.8	55	1.6	50/1	100B 4
490	2.9	57	3.0	60/1	100B 4
458	3.1	61	1.5	50/1	100B 4
430	3.3	65	1.4	50/1	100B 4
418	3.4	67	2.6	60/1	100B 4
394	3.6	70	2.4	60/1	100B 4
394	3.6	70	1.3	50/1	100B 4
364	3.9	76	1.2	50/1	100B 4
302	4.7	92	1.8	60/1	100B 4
296	4.8	94	3.5	80/1	100B 4
273	5.2	102	1.6	60/1	100B 4
268	5.3	104	3.2	80/1	100B 4
245	5.8	114	2.9	80/1	100B 4
245	5.8	111.2	1.0	45/2	100B 4
241	5.9	115	1.3	60/1	100B 4
225	6.3	121	1.2	50/2	100B 4
222	6.4	125	2.6	80/1	100B 4
222	6.4	122.7	1.0	45/2	100B 4
209	6.8	133	0.9	60/1	100B 4
192	7.4	142	1.1	50/2	100B 4
192	7.4	141.8	0.9	45/2	100B 4
180	7.9	151	2.2	60/2	100B 4
171	8.3	159	1.0	50/2	100B 4

n_2 min ⁻¹	ir	T2 Nm	FS'	AM AC	
----------------------------	----	----------	-----	----------	--

3 kW	$n_1=2840 \text{ min}^{-1}$ $n_1=1420 \text{ min}^{-1}$	90LB 2 100B 4
-------------	--	------------------

167	8.5	162.9	0.9	45/2	100B 4
154	9.2	176	0.9	50/2	100B 4
146	9.7	185.9	0.8	45/2	100B 4
141	10.1	194	1.9	60/2	100B 4
137	10.4	199	0.9	50/2	100B 4
126	11.3	217	1.7	60/2	100B 4
115	12.4	238	3.3	80/2	100B 4
115	12.4	238	1.6	60/2	100B 4
100	14.2	272	3.0	80/2	100B 4
99	14.3	274	1.4	60/2	100B 4
93	15.2	291	2.9	80/2	100B 4
92	15.5	297	1.4	60/2	100B 4
78	18.1	347	2.5	80/2	100B 4
78	18.3	351	1.1	60/2	100B 4
73	19.4	372	2.4	80/2	100B 4
72	19.7	378	1.0	60/2	100B 4
64	22.1	424	1.0	60/2	100B 4
63	22.7	435	2.1	80/2	100B 4
57	24.9	477	2.0	80/2	100B 4
56	25.3	485	0.9	60/2	100B 4
51	28.0	525	0.9	60/3	100B 4
49	28.9	554	1.7	80/2	100B 4
45	31.8	610	1.5	80/2	100B 4
44	32.5	610	3.3	100/3	100B 4
40	35.7	670	1.4	80/3	100B 4
39	36.4	683	2.9	100/3	100B 4
35	40.6	762	2.6	100/3	100B 4
35	40.3	756	1.3	80/3	100B 4
32	44.0	826	1.2	80/3	100B 4
31	45.2	848	2.3	100/3	100B 4
28	50.9	955	1.0	80/3	100B 4
27	52.8	991	2.0	100/3	100B 4
26	55.1	1034	0.9	80/3	100B 4
25	57.1	1071	3.1	120/3	100B 4
25	56.7	1064	1.9	100/3	100B 4
23	62.2	1167	2.8	120/3	100B 4
22	64.5	1210	1.6	100/3	100B 4
19.6	72.6	1362	2.4	120/3	100B 4
19.3	73.6	1381	1.4	100/3	100B 4
18.3	77.7	1458	2.3	120/3	100B 4
18.0	78.9	1480	1.3	100/3	100B 4
17.3	82.2	1542	2.1	120/3	100B 4
15.7	90.7	1702	1.9	120/3	100B 4
15.5	91.9	1724	1.2	100/3	100B 4
14.4	98.6	1850	1.1	100/3	100B 4
13.8	102.6	1925	1.7	120/3	100B 4
12.4	114.4	2147	1.5	120/3	100B 4
12.1	117.8	2210	0.9	100/3	100B 4
11.4	124.9	2344	1.4	120/3	100B 4
11.0	129.5	2430	0.8	100/3	100B 4
9.9	142.9	2681	1.2	120/3	100B 4
9.1	156.0	2927	1.1	120/3	100B 4
8.1	175.7	3297	1.0	120/3	100B 4
7.8	182.0	3415	1.0	120/3	100B 4

n_2 min ⁻¹	ir	T2 Nm	FS'	AM AC	
----------------------------	----	----------	-----	----------	---

3 kW	$n_1=2840 \text{ min}^{-1}$ $n_1=1420 \text{ min}^{-1}$	90LB 2 100B 4
-------------	--	------------------

7.2	197.1	3698	0.9	120/3	100B 4
6.9	205.0	3847	0.9	120/3	100B 4

4 kW	$n_1=2860 \text{ min}^{-1}$ $n_1=1410 \text{ min}^{-1}$	100B 2 100BL 4
-------------	--	-------------------

2383	1.2	16	1.9	40/1	100B 2
2200	1.3	17	3.3	50/1	100B 2
1907	1.5	19	3.2	50/1	100B 2
1907	1.5	19	1.8	40/1	100B 2
1682	1.7	22	1.8	40/1	100B 2
1589	1.8	23	3.4	50/1	100B 2
1430	2.0	26	3.1	50/1	100B 2
1430	2.0	26	1.7	40/1	100B 2
1300	2.2	29	1.8	40/1	100B 2
1175	1.2	32	1.0	40/1	100BL 4
1085	1.3	34	1.6	50/1	100BL 4
940	1.5	39	1.6	50/1	100BL 4
940	1.5	39	0.9	40/1	100BL 4
881	1.6	42	3.3	60/1	100BL 4
829	1.7	45	0.9	40/1	100BL 4
783	1.8	47	3.1	60/1	100BL 4
783	1.8	47	1.7	50/1	100BL 4
705	2.0	53	1.5	50/1	100BL 4
705	2.0	53	0.9	40/1	100BL 4
671	2.1	55	2.9	60/1	100BL 4
641	2.2	58	0.9	40/1	100BL 4
588	2.4	63	2.7	60/1	100BL 4
564	2.5	66	1.2	50/1	100BL 4
522	2.7	71	2.4	60/1	100BL 4
504	2.8	74	1.2	50/1	100BL 4
486	2.9	76	2.2	60/1	100BL 4
455	3.1	81	1.1	50/1	100BL 4
427	3.3	87	1.0	50/1	100BL 4
415	3.4	89	1.9	60/1	100BL 4
392	3.6	95	3.5	80/1	100BL 4
392	3.6	95	1.8	60/1	100BL 4
392	3.6	95	1.0	50/1	100BL 4
362	3.9	102	0.9	50/1	100BL 4
300	4.7	124	1.4	60/1	100BL 4
294	4.8	126	2.6	80/1	100BL 4
271	5.2	137	1.2	60/1	100BL 4
266	5.3	139	2.4	80/1	100BL 4
243	5.8	152	2.2	80/1	100BL 4
239	5.9	155	0.9	60/1	100BL 4
224	6.3	162	0.9	50/2	100BL 4
220	6.4	168	2.0	80/1	100BL 4
191	7.4	190	0.8	50/2	100BL 4
181	7.8	201	3.5	80/2	100BL 4
178	7.9	203	1.7	60/2	100BL 4
162	8.7	224	3.3	80/2	100BL 4
158	8.9	229	1.5	60/2	100BL 4



1.7 Performances motoréducteurs

1.7 Prestaciones motorreductores

1.7 Desempenhos motorreductores

n_2 min ⁻¹	ir	T2 Nm	FS'	AM AC	
----------------------------	----	----------	-----	----------	--

4 kW		$n_1 = 2860 \text{ min}^{-1}$ $n_1 = 1410 \text{ min}^{-1}$	100B 2 100BL 4
-------------	--	--	-------------------

141	10.0	257	2.9	80/2	100BL 4
140	10.1	260	1.4	60/2	100BL 4
127	11.1	286	2.7	80/2	100BL 4
125	11.3	291	1.3	60/2	100BL 4
114	12.4	319	2.5	80/2	100BL 4
114	12.4	319	1.2	60/2	100BL 4
99	14.2	365	2.2	80/2	100BL 4
93	15.2	391	2.1	80/2	100BL 4
91	15.5	399	1.0	60/2	100BL 4
78	18.1	466	1.9	80/2	100BL 4
77	18.3	471	0.8	60/2	100BL 4
73	19.4	499	1.8	80/2	100BL 4
62	22.7	584	1.6	80/2	100BL 4
57	24.9	641	1.5	80/2	100BL 4
49	28.9	744	1.3	80/2	100BL 4
48	29.1	733	2.7	100/3	100BL 4
44	31.8	818	1.1	80/2	100BL 4
43	32.5	819	2.4	100/3	100BL 4
39	36.4	917	2.2	100/3	100BL 4
39	35.7	899	1.1	80/3	100BL 4
35	40.7	1025	3.2	120/3	100BL 4
35	40.6	1023	1.9	100/3	100BL 4
35	40.3	1015	1.0	80/3	100BL 4
32	44.0	1109	0.9	80/3	100BL 4
31	45.7	1151	2.9	120/3	100BL 4
31	45.2	1139	1.7	100/3	100BL 4
28	50.9	1282	2.6	120/3	100BL 4
27	52.8	1330	1.5	100/3	100BL 4
25	57.1	1439	2.3	120/3	100BL 4
25	56.7	1429	1.4	100/3	100BL 4
23	62.2	1567	2.1	120/3	100BL 4
22	64.5	1625	1.2	100/3	100BL 4
19.4	72.6	1829	1.8	120/3	100BL 4
19.2	73.6	1854	1.1	100/3	100BL 4
18.1	77.7	1958	1.7	120/3	100BL 4
17.9	78.9	1988	1.0	100/3	100BL 4
17.2	82.2	2071	1.6	120/3	100BL 4
15.5	90.7	2285	1.4	120/3	100BL 4
15.3	91.9	2315	0.9	100/3	100BL 4
13.7	102.6	2585	1.3	120/3	100BL 4
12.3	114.4	2882	1.1	120/3	100BL 4
11.3	124.9	3147	1.0	120/3	100BL 4
9.9	142.9	3600	0.9	120/3	100BL 4
9.0	156.0	3931	0.8	120/3	100BL 4

5.5 kW		$n_1 = 2880 \text{ min}^{-1}$ $n_1 = 1440 \text{ min}^{-1}$ $n_1 = 1400 \text{ min}^{-1}$	112B 2 132S 4 112BL 4
---------------	--	---	-----------------------------

2400	1.2	21	1.4	40/1*	112B 2
2215	1.3	23	2.4	50/1	112B 2
1920	1.5	27	2.4	50/1	112B 2
1920	1.5	27	1.3	40/1*	112B 2

n_2 min ⁻¹	ir	T2 Nm	FS'	AM AC	
----------------------------	----	----------	-----	----------	--

5.5 kW		$n_1 = 2880 \text{ min}^{-1}$ $n_1 = 1440 \text{ min}^{-1}$ $n_1 = 1400 \text{ min}^{-1}$	112B 2 132S 4 112BL 4
---------------	--	---	-----------------------------

1694	1.7	30	1.3	40/1*	112B 2
1600	1.8	32	2.5	50/1	112B 2
1440	2.0	35	2.3	50/1	112B 2
1440	2.0	35	1.3	40/1*	112B 2
1309	2.2	39	1.3	40/1*	112B 2
1077	1.3	47	2.7	60/1	112BL 4
1077	1.3	47	1.2	50/1	112BL 4
933	1.5	55	1.2	50/1	112BL 4
875	1.6	58	2.4	60/1	112BL 4
778	1.8	66	2.2	60/1	112BL 4
778	1.8	66	1.2	50/1	112BL 4
700	2.0	73	1.1	50/1	112BL 4
667	2.1	76	2.1	60/1	112BL 4
583	2.4	87	1.9	60/1	112BL 4
560	2.5	91	0.9	50/1	112BL 4
519	2.7	98	3.4	80/1	112BL 4
519	2.7	98	1.7	60/1	112BL 4
500	2.8	102	0.8	50/1	112BL 4
483	2.9	106	3.1	80/1	112BL 4
483	2.9	106	1.6	60/1	112BL 4
424	3.3	120	2.7	80/1	112BL 4
412	3.4	124	1.4	60/1	112BL 4
389	3.6	131	2.5	80/1	112BL 4
389	3.6	131	1.3	60/1	112BL 4
298	4.7	171	1.0	60/1	112BL 4
292	4.8	175	1.9	80/1	112BL 4
269	5.2	189	0.9	60/1	112BL 4
264	5.3	193	1.7	80/1	112BL 4
241	5.8	211	1.6	80/1	112BL 4
219	6.4	233	1.4	80/1	112BL 4
209	6.9	244	2.0	100/1	132S 4
192	7.5	265	1.8	100/1	132S 4
179	7.8	278	2.5	80/2	112BL 4
177	7.9	282	1.2	60/2	112BL 4
161	8.7	310	2.3	80/2	112BL 4
157	8.9	317	1.1	60/2	112BL 4
140	10.0	356	2.1	80/2	112BL 4
139	10.1	360	1.0	60/2	112BL 4
126	11.1	396	1.9	80/2	112BL 4
113	12.4	442	1.8	80/2	112BL 4
113	12.4	442	0.8	60/2	112BL 4
99	14.2	506	1.6	80/2	112BL 4
92	15.2	542	1.6	80/2	112BL 4
91	15.9	551	3.1	100/2	132S 4
82	17.6	610	2.9	100/2	132S 4
77	18.1	645	1.3	80/2	112BL 4
72	19.9	690	2.6	100/2	132S 4
72	19.4	691	1.3	80/2	112BL 4
65	22.2	769	2.4	100/2	132S 4
62	22.7	809	1.1	80/2	112BL 4
60	24.2	839	2.3	100/2	132S 4
56	24.9	887	1.1	80/2	112BL 4
48	28.9	1030	0.9	80/2	112BL 4
44	31.8	1133	0.8	80/2	112BL 4

n_2 min ⁻¹	ir	T2 Nm	FS'	AM AC	
----------------------------	----	----------	-----	----------	--

5.5 kW		$n_1 = 2880 \text{ min}^{-1}$ $n_1 = 1440 \text{ min}^{-1}$ $n_1 = 1400 \text{ min}^{-1}$	112B 2 132S 4 112BL 4
---------------	--	---	-----------------------------

43	32.5	1134	1.8	100/3	112BL 4
41	35.3	1223	1.6	100/2	132S 4
39	37.0	1282	2.3	120/2	132S 4
38	38.3	1327	1.5	100/2	132S 4
34	40.6	1417	1.4	100/3	112BL 4
34	40.7	1420	2.3	120/3	112BL 4
31	45.2	1577	1.3	100/3	112BL 4
31	45.7	1595	2.1	120/3	112BL 4
28	50.9	1776	1.9	120/3	112BL 4
27	52.8	1842	1.1	100/3	112BL 4
25	56.7	1978	1.0	100/3	112BL 4
25	57.1	1992	1.7	120/3	112BL 4
23	62.2	2170	1.5	120/3	112BL 4
22	64.5	2251	0.9	100/3	112BL 4
19.3	72.6	2533	1.3	120/3	112BL 4
18.0	77.7	2711	1.2	120/3	112BL 4
15.4	90.7	3165	1.0	120/3	112BL 4
13.6	102.6	3580	0.9	120/3	112BL 4
12.2	114.4	3992	0.8	120/3	112BL 4

7.5 kW		$n_1 = 2890 \text{ min}^{-1}$ $n_1 = 2860 \text{ min}^{-1}$ $n_1 = 1440 \text{ min}^{-1}$	132SL 2 112BL 2 132M 4
---------------	--	---	------------------------------

2383	1.2	29	1.0	40/1*	112BL 2
2200	1.3	32	1.7	50/1*	112BL 2
1907	1.5	36	1.7	50/1*	112BL 2
1907	1.5	36	1.0	40/1*	112BL 2
1682	1.7	41	1.0	40/1*	112BL 2
1606	1.8	43	3.4	60/1	132SL 2
1589	1.8	44	3.3	60/1	112BL 2
1589	1.8	44	1.8	50/1*	112BL 2
1430	2.0	49	1.6	50/1*	112BL 2
1430	2.0	49	0.9	40/1*	112BL 2
1362	2.1	51	3.1	60/1	112BL 2
1300	2.2	53	0.9	40/1*	112BL 2
1204	2.4	58	2.9	60/1	132SL 2
1144	2.5	61	1.3	50/1*	112BL 2
1108	1.3	63	2.1	60/1	132M 4
1059	2.7	66	2.6	60/1	112BL 2
1021	2.8	68	1.2	50/1*	112BL 2
986	2.9	70	2.4	60/1	112BL 2
923	3.1	75	1.2	50/1*	112BL 2
800	1.8	87	3.2	80/1	132M 4
800	1.8	87	1.7	60/1	132M 4
794	3.6	87	1.0	50/1*	112BL 2
733	3.9	95	0.9	50/1*	112BL 2
720	2.0	96	3.2	80/1	132M 4
686	2.1	101	1.6	60/1	132M 4
600	2.4	116	2.8	80/1	132M 4
600	2.4	116	1.5	60/1	132M 4
533	2.7	130	2.5	80/1	132M 4



1.7 Performances motoréducteurs

1.7 Prestaciones motorreductores

1.7 Desempenhos motorreductores

n ₂ min ⁻¹	ir	T2 Nm	FS'	AM AC	
-------------------------------------	----	----------	-----	----------	--

7.5 kW	n ₁ = 2890 min ⁻¹	132SL 2
	n ₁ = 2860 min ⁻¹	112BL 2
	n ₁ = 1440 min ⁻¹	132M 4

533	2.7	130	1.3	60/1	132M 4
497	2.9	140	2.4	80/1	132M 4
497	2.9	140	1.2	60/1	132M 4
436	3.3	159	2.1	80/1	132M 4
424	3.4	164	1.0	60/1	132M 4
400	3.6	174	1.9	80/1	132M 4
400	3.6	174	1.0	60/1	132M 4
369	3.9	188	3.2	100/1	132M 4
362	7.9	188	1.5	60/2	112BL 2
321	8.9	212	1.4	60/2	112BL 2
300	4.8	232	1.4	80/1	132M 4
272	5.3	256	1.3	80/1	132M 4
267	5.4	261	2.0	100/1	132M 4
253	11.3	269	1.1	60/2	112BL 2
248	5.8	280	1.2	80/1	132M 4
244	5.9	285	1.9	100/1	132M 4
231	12.4	295	1.1	60/2	112BL 2
225	6.4	309	1.1	80/1	132M 4
209	6.9	333	1.4	100/1	132M 4
200	14.3	340	1.0	60/2	112BL 2
192	7.5	362	1.3	100/1	132M 4
185	7.8	369	1.9	80/2	132M 4
182	7.9	373	0.9	60/2	132M 4
166	8.7	411	1.8	80/2	132M 4
162	8.9	421	3.6	100/2	132M 4
162	8.9	421	0.8	60/2	132M 4
145	9.9	468	3.3	100/2	132M 4
144	10.0	473	1.6	80/2	132M 4
130	11.1	525	3.0	100/2	132M 4
130	11.1	525	1.5	80/2	132M 4
119	12.1	572	2.8	100/2	132M 4
116	12.4	586	1.3	80/2	132M 4
102	14.1	666	2.5	100/2	132M 4
101	14.2	671	1.2	80/2	132M 4
95	15.2	718	1.2	80/2	132M 4
91	15.9	751	2.3	100/2	132M 4
82	17.6	832	2.1	100/2	132M 4
80	18.1	855	1.0	80/2	132M 4
75	19.3	912	3.3	120/2	132M 4
74	19.4	917	1.0	80/2	132M 4
72	19.9	940	1.9	100/2	132M 4
69	21.0	992	3.0	120/2	132M 4
65	22.1	1044	2.9	120/2	132M 4
65	22.2	1049	1.8	100/2	132M 4
63	22.7	1073	0.8	80/2	132M 4
62	23.1	1092	2.7	120/2	132M 4
60	24.0	1134	2.6	120/2	132M 4
60	24.2	1144	1.7	100/2	132M 4
53	27.0	1276	2.4	120/2	132M 4
51	28.3	1337	1.4	100/2	132M 4
50	28.9	1366	2.2	120/2	132M 4
49	29.1	1346	1.5	100/3	132M 4
49	29.6	1399	2.1	120/2	132M 4
48	30.3	1432	1.3	100/2	132M 4

n ₂ min ⁻¹	ir	T2 Nm	FS'	AM AC	
-------------------------------------	----	----------	-----	----------	--

7.5 kW	n ₁ = 2890 min ⁻¹	132SL 2
	n ₁ = 2860 min ⁻¹	112BL 2
	n ₁ = 1440 min ⁻¹	132M 4

44	32.5	1503	1.3	100/3	132M 4
43	33.7	1592	1.9	120/2	132M 4
41	35.3	1668	1.2	100/2	132M 4
40	36.4	1684	1.2	100/3	132M 4
39	37.0	1748	1.7	120/2	132M 4
38	38.3	1810	1.1	100/2	132M 4
35	40.6	1878	1.1	100/3	132M 4
35	40.7	1883	1.8	120/3	132M 4
32	45.2	2091	0.9	100/3	132M 4
32	45.7	2114	1.6	120/3	132M 4
28	50.9	2355	1.4	120/3	132M 4
27	52.8	2442	0.8	100/3	132M 4
25	57.1	2641	1.2	120/3	132M 4
23	62.2	2877	1.1	120/3	132M 4
19.8	72.6	3358	1.0	120/3	132M 4
18.5	77.7	3594	0.9	120/3	132M 4
17.5	82.2	3802	0.9	120/3	132M 4

9.2 kW	n ₁ = 1450 min ⁻¹	132ML 4
---------------	---	---------

1115	1.3	76	1.7	60/1*	132ML 4
1036	1.4	82	3.3	80/1	132ML 4
906	1.6	94	1.5	60/1*	132ML 4
806	1.8	106	2.6	80/1	132ML 4
806	1.8	106	1.4	60/1*	132ML 4
725	2.0	118	2.6	80/1	132ML 4
690	2.1	123	1.3	60/1*	132ML 4
604	2.4	141	2.3	80/1	132ML 4
604	2.4	141	1.2	60/1*	132ML 4
537	2.7	159	2.1	80/1	132ML 4
537	2.7	159	1.1	60/1*	132ML 4
500	2.9	170	1.9	80/1	132ML 4
500	2.9	170	1.0	60/1*	132ML 4
439	3.3	194	1.7	80/1	132ML 4
426	3.4	200	0.9	60/1*	132ML 4
403	3.6	212	1.6	80/1	132ML 4
403	3.6	212	0.8	60/1*	132ML 4
372	3.9	229	2.6	100/1	132ML 4
302	4.8	282	1.2	80/1	132ML 4
250	5.8	341	1.0	80/1	132ML 4
246	5.9	347	1.5	100/1	132ML 4
227	6.4	376	0.9	80/1	132ML 4
210	6.9	406	1.2	100/1	132ML 4
186	7.8	449	1.6	80/2	132ML 4
184	7.9	455	3.2	100/2	132ML 4
167	8.7	501	1.5	80/2	132ML 4
163	8.9	512	2.9	100/2	132ML 4
146	9.9	570	2.7	100/2	132ML 4
145	10.0	576	1.3	80/2	132ML 4
131	11.1	639	2.5	100/2	132ML 4

n ₂ min ⁻¹	ir	T2 Nm	FS'	AM AC	
-------------------------------------	----	----------	-----	----------	--

9.2 kW	n ₁ = 1450 min ⁻¹	132ML 4
---------------	---	---------

131	11.1	639	1.2	80/2	132ML 4
120	12.1	697	2.3	100/2	132ML 4
117	12.4	714	1.1	80/2	132ML 4
103	14.1	812	2.1	100/2	132ML 4
102	14.2	817	1.0	80/2	132ML 4
95	15.2	875	1.0	80/2	132ML 4
91	15.9	915	1.9	100/2	132ML 4
82	17.6	1013	1.8	100/2	132ML 4
82	17.7	1019	2.9	120/2	132ML 4
80	18.1	1042	0.8	80/2	132ML 4
73	19.9	1146	1.6	100/2	132ML 4
65	22.2	1278	1.5	100/2	132ML 4
63	23.1	1330	2.3	120/2	132ML 4
51	28.3	1629	1.2	100/2	132ML 4
50	28.9	1664	1.8	120/2	132ML 4
43	33.7	1940	1.5	120/2	132ML 4
41	35.3	2032	0.9	100/2	132ML 4
36	40.6	2288	0.9	100/3	132ML 4
36	40.7	2294	1.4	120/3	132ML 4
28	50.9	2868	1.2	120/3	132ML 4
23	62.2	3505	0.9	120/3	132ML 4

11 kW	n ₁ = 2940 min ⁻¹	132M 2
	n ₁ = 1455 min ⁻¹	160M 4

2450	1.2	42	6.3	80/1	132M 2
2262	1.3	45	2.9	60/1*	132M 2
1838	1.6	55	2.5	60/1*	132M 2
1633	1.8	62	2.3	60/1*	132M 2
1400	2.1	73	2.2	60/1*	132M 2
1225	2.4	83	2.0	60/1*	132M 2
1213	1.2	84	3.1	80/1	160M 4
1089	2.7	94	3.5	80/1	132M 2
1089	2.7	94	1.8	60/1*	132M 2
1039	1.4	98	2.8	80/1	160M 4
1014	2.9	101	1.7	60/1*	132M 2
891	3.3	114	2.9	80/1	132M 2
865	3.4	118	1.4	60/1*	132M 2
808	1.8	126	2.2	80/1	160M 4
728	2.0	140	2.2	80/1	160M 4
626	4.7	163	1.0	60/1*	132M 2
606	2.4	168	2.0	80/1	160M 4
565	5.2	180	0.9	60/1*	132M 2
539	2.7	189	1.7	80/1	160M 4
502	2.9	203	1.6	80/1	160M 4
485	3.0	210	2.9	100/1	160M 4
441	3.3	231	1.4	80/1	160M 4
416	3.5	245	2.4	100/1	160M 4
404	3.6	252	1.3	80/1	160M 4
373	3.9	273	2.2	100/1	160M 4
372	7.9	268	1.1	60/2*	132M 2



1.7 Performances motorréducteurs

n ₂ min ⁻¹	ir	T2 Nm	FS'	AM AC	
----------------------------------	----	-------	-----	-------	--

11 kW	n ₁ = 2940 min ⁻¹ n ₁ = 1455 min ⁻¹	132M 2 160M 4
--------------	--	------------------

338	8.7	295	2.1	80/2	132M 2
330	8.9	302	1.0	60/2*	132M 2
303	4.8	336	1.0	80/1	160M 4
275	5.3	371	0.9	80/1	160M 4
269	5.4	378	1.4	100/1	160M 4
265	11.1	377	1.7	80/2	132M 2
251	5.8	406	0.8	80/1	160M 4
247	5.9	413	1.3	100/1	160M 4
211	6.9	473	2.9	100/2	160M 4
211	6.9	483	1.0	100/1	160M 4
194	7.5	514	2.7	100/2	160M 4
194	7.5	525	0.9	100/1	160M 4
187	7.8	535	1.3	80/2	160M 4
184	7.9	542	2.7	100/2	160M 4
167	8.7	597	1.2	80/2	160M 4
163	8.9	610	2.4	100/2	160M 4
147	9.9	679	2.3	100/2	160M 4
146	10.0	686	1.1	80/2	160M 4
137	10.6	727	3.1	120/2	160M 4
131	11.1	761	2.1	100/2	160M 4
131	11.1	761	1.0	80/2	160M 4
120	12.1	830	1.9	100/2	160M 4
117	12.4	851	0.9	80/2	160M 4
103	14.1	967	3.1	120/2	160M 4
103	14.1	967	1.7	100/2	160M 4
102	14.2	974	0.8	80/2	160M 4
96	15.2	1043	0.8	80/2	160M 4
92	15.9	1091	1.6	100/2	160M 4
83	17.6	1207	1.5	100/2	160M 4
82	17.7	1214	2.5	120/2	160M 4
75	19.3	1324	2.3	120/2	160M 4
73	19.9	1365	1.3	100/2	160M 4
66	22.1	1516	2.0	120/2	160M 4
66	22.2	1523	1.2	100/2	160M 4
61	24.0	1646	1.8	120/2	160M 4
60	24.2	1660	1.2	100/2	160M 4
51	28.3	1941	1.0	100/2	160M 4
50	28.9	1982	1.5	120/2	160M 4
43	33.7	2311	1.3	120/2	160M 4
39	37.0	2538	1.2	120/2	160M 4
32	90.7	3014	1.0	120/3	132M 2

15 kW	n ₁ = 2930 min ⁻¹ n ₁ = 2900 min ⁻¹ n ₁ = 1455 min ⁻¹	160MB 2 132ML 2 160L 4
--------------	---	------------------------------

2442	1.2	57	4.6	80/1*	160MB 2
2231	1.3	62	2.1	60/1*	132ML 2
1813	1.6	77	1.8	60/1*	132ML 2
1611	1.8	86	3.2	80/1*	132ML 2
1611	1.8	86	1.7	60/1*	132ML 2
1450	2.0	96	3.2	80/1*	132ML 2

1.7 Prestaciones motorreductores

n ₂ min ⁻¹	ir	T2 Nm	FS'	AM AC	
----------------------------------	----	-------	-----	-------	--

15 kW	n ₁ = 2930 min ⁻¹ n ₁ = 2900 min ⁻¹ n ₁ = 1455 min ⁻¹	160MB 2 132ML 2 160L 4
--------------	---	------------------------------

1381	2.1	101	1.6	60/1*	132ML 2
1213	1.2	115	2.3	80/1*	160L 4
1208	2.4	115	1.5	60/1*	132ML 2
1074	2.7	129	1.3	60/1*	132ML 2
1039	1.4	134	2.0	80/1*	160L 4
879	3.3	158	2.1	80/1*	132ML 2
853	3.4	163	1.0	60/1*	132ML 2
808	1.8	172	1.6	80/1*	160L 4
806	3.6	172	1.0	60/1*	132ML 2
766	1.9	181	2.7	100/1	160L 4
728	2.0	191	1.6	80/1*	160L 4
661	2.2	210	2.9	100/1	160L 4
606	2.4	229	1.4	80/1*	160L 4
539	2.7	258	1.3	80/1*	160L 4
502	2.9	277	1.2	80/1*	160L 4
485	3.0	287	2.1	100/1	160L 4
441	3.3	315	1.0	80/1*	160L 4
416	3.5	334	1.8	100/1	160L 4
404	3.6	344	1.0	80/1*	160L 4
393	3.7	346	3.5	100/2	160L 4
373	3.9	372	1.6	100/1	160L 4
372	7.8	366	1.6	80/2*	132ML 2
333	8.7	408	1.5	80/2*	132ML 2
297	4.9	458	2.8	100/2	160L 4
290	10.0	469	1.3	80/2*	132ML 2
269	5.4	516	1.0	100/1	160L 4
261	11.1	521	2.5	100/2	132ML 2
261	11.1	521	1.2	80/2*	132ML 2
247	5.9	563	0.9	100/1	160L 4
239	6.1	571	3.5	120/2	160L 4
234	12.4	582	1.1	80/2*	132ML 2
211	6.9	645	2.1	100/2	160L 4
194	7.5	701	2.0	100/2	160L 4
189	7.7	720	3.1	120/2	160L 4
187	7.8	730	1.0	80/2*	160L 4
171	8.5	795	3.1	120/2	160L 4
167	8.7	814	0.9	80/2*	160L 4
163	8.9	832	1.8	100/2	160L 4
147	9.9	926	1.7	100/2	160L 4
137	10.6	991	2.3	120/2	160L 4
131	11.1	1038	1.5	100/2	160L 4
127	11.5	1076	2.8	120/2	160L 4
120	12.1	1132	1.4	100/2	160L 4
103	14.1	1319	2.3	120/2	160L 4
103	14.1	1319	1.3	100/2	160L 4
92	15.9	1487	1.2	100/2	160L 4
83	17.6	1646	1.1	100/2	160L 4
82	17.7	1655	1.8	120/2	160L 4
75	19.3	1805	1.7	120/2	160L 4
73	19.9	1861	1.0	100/2	160L 4
69	21.0	1964	1.5	120/2	160L 4
66	22.1	2067	1.5	120/2	160L 4
66	22.2	2076	0.9	100/2	160L 4
63	23.1	2161	1.4	120/2	160L 4

1.7 Desempenhos motorreductores

n ₂ min ⁻¹	ir	T2 Nm	FS'	AM AC	
----------------------------------	----	-------	-----	-------	--

15 kW	n ₁ = 2930 min ⁻¹ n ₁ = 2900 min ⁻¹ n ₁ = 1455 min ⁻¹	160MB 2 132ML 2 160L 4
--------------	---	------------------------------

61	24.0	2245	1.3	120/2	160L 4
60	24.2	2263	0.9	100/2	160L 4
54	27.0	2525	1.2	120/2	160L 4
50	28.9	2703	1.1	120/2	160L 4
49	29.6	2769	1.1	120/2	160L 4
43	33.7	3152	1.0	120/2	160L 4
39	37.0	3461	0.9	120/2	160L 4

18.5 kW	n ₁ = 2910 min ⁻¹ n ₁ = 1460 min ⁻¹ n ₁ = 970 min ⁻¹	160L 2 180M 4 200L 6
----------------	--	----------------------------

2425	1.2	71	3.7	80/1*	160L 2
2079	1.4	82	3.3	80/1*	160L 2
1617	1.8	106	2.6	80/1*	160L 2
1455	2.0	118	2.6	80/1*	160L 2
1213	2.4	141	2.3	80/1*	160L 2
1123	1.3	153	3.1	100/1	180M 4
882	3.3	194	1.7	80/1*	160L 2
808	3.6	212	1.6	80/1*	160L 2
768	1.9	223	2.2	100/1	180M 4
664	2.2	258	2.3	100/1	180M 4
606	4.8	283	1.2	80/1*	160L 2
549	5.3	312	1.1	80/1*	160L 2
539	5.4	318	1.7	100/1	160L 2
502	5.8	342	1.0	80/1*	160L 2
487	3.0	352	1.7	100/1	180M 4
455	6.4	377	0.9	80/1*	160L 2
417	3.5	411	1.5	100/1	180M 4
395	3.7	425	2.9	100/2	180M 4
374	3.9	458	1.3	100/1	180M 4
373	7.8	450	1.3	80/2*	160L 2
334	8.7	502	1.2	80/2*	160L 2
298	4.9	563	2.3	100/2	180M 4
291	10.0	577	1.1	80/2*	160L 2
281	5.2	598	3.0	120/2	180M 4
270	5.4	634	0.8	100/1	180M 4
262	11.1	640	1.0	80/2*	160L 2
239	6.1	701	2.9	120/2	180M 4
212	6.9	793	1.7	100/2	180M 4
195	7.5	862	1.6	100/2	180M 4
190	7.7	885	2.5	120/2	180M 4
185	7.9	908	1.6	100/2	180M 4
172	8.5	977	2.6	120/2	180M 4
164	8.9	1023	1.5	100/2	180M 4
147	9.9	1138	1.3	100/2	180M 4
138	10.6	1219	1.9	120/2	180M 4
132	11.1	1276	1.2	100/2	180M 4
127	11.5	1322	2.3	120/2	180M 4
121	12.1	1391	1.2	100/2	180M 4
104	14.1	1621	1.9	120/2	180M 4
104	14.1	1621	1.0	100/2	180M 4



1.7 Performances motoréducteurs

1.7 Prestaciones motorreductores

1.7 Desempenhos motorreductores

n_2 min ⁻¹	ir	T2 Nm	FS'	AM AC	
----------------------------	----	----------	-----	----------	--

18.5 kW	$n_1 = 2910 \text{ min}^{-1}$	160L 2
	$n_1 = 1460 \text{ min}^{-1}$	180M 4
	$n_1 = 970 \text{ min}^{-1}$	200L 6

92	15.9	1828	0.9	100/2	180M 4
83	17.6	2023	0.9	100/2	180M 4
82	17.7	2035	1.5	120/2	180M 4
70	21.0	2414	1.2	120/2	180M 4
61	24.0	2759	1.1	120/2	180M 4
51	28.9	3322	0.9	120/2	180M 4
46	21.0	3634	0.8	120/2	200L 6

22 kW	$n_1 = 2925 \text{ min}^{-1}$	180M 2
	$n_1 = 1460 \text{ min}^{-1}$	180L 4
	$n_1 = 975 \text{ min}^{-1}$	200L 6

2250	1.3	91	5.3	100/1*	180M 2
1539	1.9	132	3.7	100/1*	180M 2
1330	2.2	153	3.9	100/1*	180M 2
1219	2.4	164	5.6	100/2	180M 2
1123	1.3	181	2.6	100/1*	180L 4
1083	2.7	184	5.2	100/2	180M 2
975	3.0	209	2.9	100/1*	180M 2
836	3.5	244	2.5	100/1*	180M 2
768	1.9	265	1.8	100/1*	180L 4
664	2.2	307	2.0	100/1*	180L 4
608	2.4	328	3.3	100/2	180L 4
541	2.7	369	3.1	100/2	180L 4
487	3.0	419	1.4	100/1*	180L 4
417	3.5	489	1.2	100/1*	180L 4
395	3.7	506	2.4	100/2	180L 4
374	3.9	533	3.2	120/2	180L 4
374	3.9	544	1.1	100/1*	180L 4
298	4.9	670	1.9	100/2	180L 4
281	5.2	711	2.5	120/2	180L 4
239	6.1	834	2.4	120/2	180L 4
212	6.9	943	1.4	100/2	180L 4
195	7.5	1025	1.4	100/2	180L 4
190	7.7	1053	2.1	120/2	180L 4
185	7.9	1080	1.3	100/2	180L 4
172	8.5	1162	2.2	120/2	180L 4
164	8.9	1217	1.2	100/2	180L 4
147	9.9	1353	1.1	100/2	180L 4
138	10.6	1449	1.6	120/2	180L 4
132	11.1	1517	1.0	100/2	180L 4
127	11.5	1572	1.9	120/2	180L 4
121	12.1	1654	1.0	100/2	180L 4
104	14.1	1928	1.6	120/2	180L 4
104	14.1	1928	0.9	100/2	180L 4
92	10.6	2170	1.4	120/2	200L 6
82	17.7	2420	1.2	120/2	180L 4
76	19.3	2638	1.1	120/2	180L 4
70	21.0	2871	1.0	120/2	180L 4
66	22.1	3021	1.0	120/2	180L 4
61	24.0	3281	0.9	120/2	180L 4
54	27.0	3691	0.8	120/2	180L 4

n_2 min ⁻¹	ir	T2 Nm	FS'	AM AC	
----------------------------	----	----------	-----	----------	--

30 kW	$n_1 = 2945 \text{ min}^{-1}$	200L 2
	$n_1 = 1465 \text{ min}^{-1}$	200L 4

2265	1.3	123	3.9	100/1*	200L 2
1550	1.9	179	2.7	100/1*	200L 2
1339	2.2	208	2.9	100/1*	200L 2
1227	2.4	222	4.1	100/2*	200L 2
1127	1.3	247	1.9	100/1*	200L 4
1091	2.7	250	3.8	100/2*	200L 2
982	3.0	283	2.1	100/1*	200L 2
841	3.5	330	1.8	100/1*	200L 2
796	3.7	342	3.0	100/2*	200L 2
771	1.9	360	1.4	100/1*	200L 4
666	2.2	417	1.4	100/1*	200L 4
610	2.4	446	2.4	100/2*	200L 4
543	2.7	502	2.3	100/2*	200L 4
523	2.8	520	3.3	120/2	200L 4
488	3.0	569	1.1	100/1*	200L 4
419	3.5	664	0.9	100/1*	200L 4
396	3.7	687	1.8	100/2*	200L 4
376	3.9	725	2.3	120/2	200L 4
376	3.9	740	0.8	100/1*	200L 4
299	4.9	910	1.4	100/2*	200L 4
282	5.2	966	1.9	120/2	200L 4
240	6.1	1133	1.8	120/2	200L 4
212	6.9	1282	1.1	100/2*	200L 4
195	7.5	1393	1.0	100/2*	200L 4
190	7.7	1431	1.5	120/2	200L 4
185	7.9	1468	1.0	100/2*	200L 4
172	8.5	1579	1.6	120/2	200L 4
165	8.9	1653	0.9	100/2*	200L 4
148	9.9	1839	0.8	100/2*	200L 4
138	10.6	1969	1.2	120/2	200L 4
127	11.5	2137	1.4	120/2	200L 4
104	14.1	2620	1.1	120/2	200L 4
83	17.7	3288	0.9	120/2	200L 4

37 kW	$n_1 = 2950 \text{ min}^{-1}$	200L 2
	$n_1 = 1475 \text{ min}^{-1}$	225S 4

2269	1.3	151	3.2	100/1*	200L 2
1553	1.9	221	2.2	100/1*	200L 2
1341	2.2	256	2.3	100/1*	200L 2
1229	2.4	273	3.3	100/2*	200L 2
1093	2.7	307	3.1	100/2*	200L 2
983	3.0	349	1.7	100/1*	200L 2
843	3.5	407	1.5	100/1*	200L 2
797	3.7	421	2.4	100/2*	200L 2
756	3.9	453	1.3	100/1*	200L 2
602	4.9	558	1.9	100/2*	200L 2
567	5.2	592	2.5	120/2*	200L 2
546	5.4	627	0.8	100/1*	200L 2
527	2.8	637	2.7	120/2*	225S 4
484	6.1	694	2.3	120/2*	200L 2

n_2 min ⁻¹	ir	T2 Nm	FS'	AM AC	
----------------------------	----	----------	-----	----------	--

37 kW	$n_1 = 2950 \text{ min}^{-1}$	200L 2
	$n_1 = 1475 \text{ min}^{-1}$	225S 4

428	6.9	785	1.4	100/2*	200L 2
393	7.5	853	1.4	100/2*	200L 2
378	3.9	888	1.9	120/2*	225S 4
331	8.9	1013	1.2	100/2*	200L 2
284	5.2	1183	1.5	120/2*	225S 4
244	12.1	1377	1.0	100/2*	200L 2
242	6.1	1388	1.4	120/2*	225S 4
192	7.7	1752	1.3	120/2*	225S 4
174	8.5	1934	1.3	120/2*	225S 4
139	10.6	2412	0.9	120/2*	225S 4
128	11.5	2617	1.1	120/2*	225S 4
105	14.1	3209	0.9	120/2*	225S 4

45 kW	$n_1 = 2945 \text{ min}^{-1}$	225M 2
	$n_1 = 1475 \text{ min}^{-1}$	225M 4

1052	2.8	388	3.6	120/2*	225M 2
755	3.9	541	2.6	120/2*	225M 2
566	5.2	721	2.0	120/2*	225M 2
527	2.8	775	2.2	120/2*	225M 4
483	6.1	846	1.9	120/2*	225M 2
382	7.7	1067	1.7	120/2*	225M 2
378	3.9	1079	1.6	120/2*	225M 4
346	8.5	1178	1.7	120/2*	225M 2
284	5.2	1439	1.3	120/2*	225M 4
278	10.6	1469	1.5	120/2*	225M 2
256	11.5	1594	1.5	120/2*	225M 2
242	6.1	1688	1.2	120/2*	225M 4
209	14.1	1955	1.2	120/2*	225M 2
192	7.7	2131	1.0	120/2*	225M 4
174	8.5	2353	1.1	120/2*	225M 4
153	19.3	2676	0.9	120/2*	225M 2
140	21.0	2911	0.8	120/2*	225M 2

N.B.
Toutes les puissances indiquées se réfèrent à la puissance mécanique des réducteurs.
Pour les réducteurs marqués d'un (*), il s'avère nécessaire de vérifier la puissance limite thermique selon les indications reportées dans le par. A-1.5

Nota:
Todas las potencias indicadas se refieren a la potencia mecánica de los reductores.
Para los reductores marcados con (*) se recomienda efectuar el control de la potencia límite térmico según las indicaciones del párr. A-1.5

OBS.
Todas as potências indicadas referem-se à potência mecânica dos reductores.
Para reductores marcados com (*) é oportuno efetuar o controle da potência do limite térmico segundo as indicações do par. A-1.5.



1.8 Dimensions

1.8 Dimensiones

1.8 Dimensões



Dimensions réducteurs
Dimensiones reductoros
Dimensões redutores

AM/1 - AR/1 - AC/1

ARP (32)

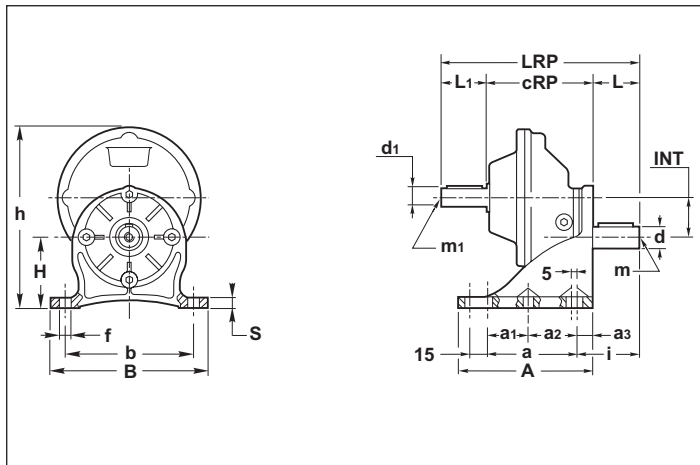

ARP (40 - 100)

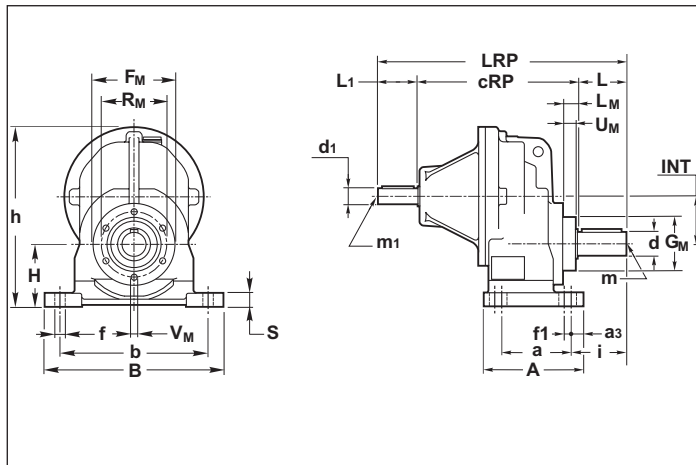

ACP (32)

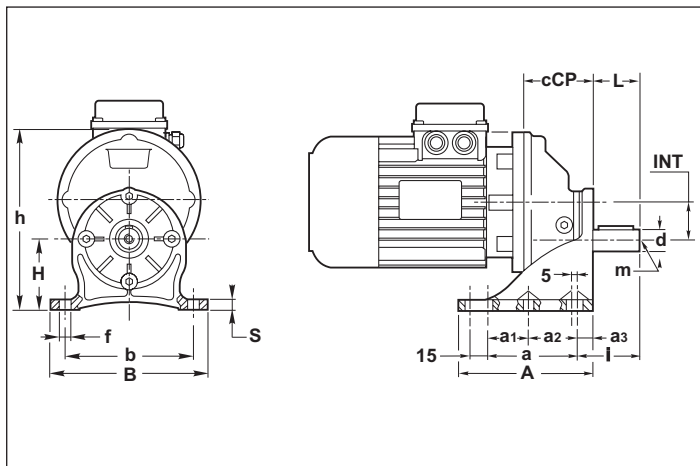

ACP (40 - 100)

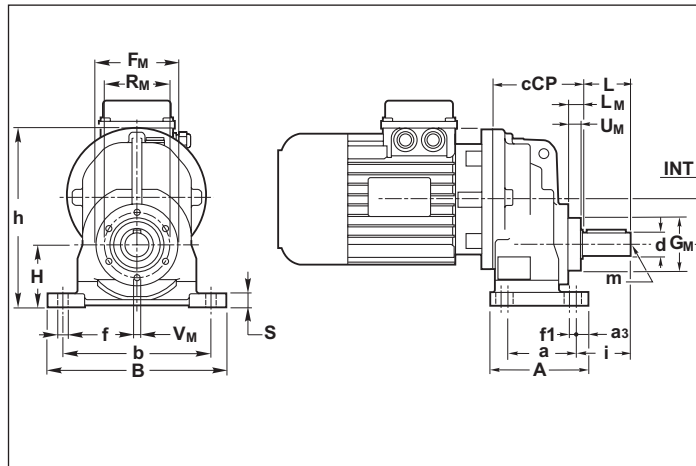

AMP (32)

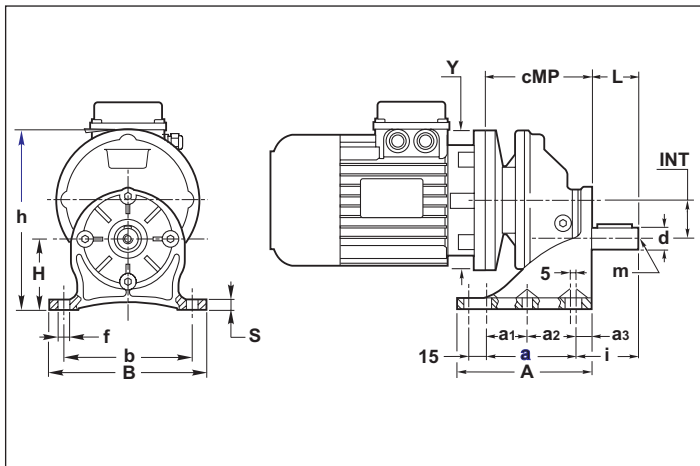

AMP (40 - 100)

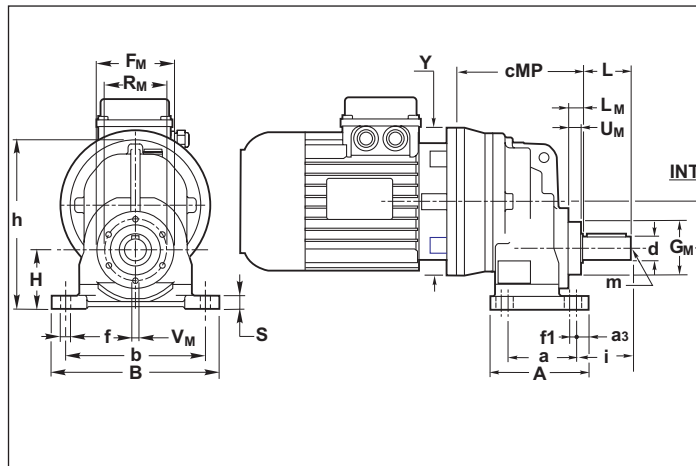



1.8 Dimension

1.8 Dimensiones

1.8 Dimensões

AM AC AR	a	a ₁	a ₂	a ₃	A	b	B	cRP	d h6	d ₁ j6	F _M	f	f1	G _M	h	H	i	L	L ₁	L _M	LRP	m	m ₁	R _M	S	U _M	V _M	INT
32	77	35	42	13	115	110	135	92	19 (14)	16	—	9	5	—	153	60	53 (43)	40 (30)	40	—	172 (162)	M6 (M6)	M6	—	9	—	—	33
40	45	—	—	12	85	105	130	141	19 (20)	16	82	8.5	2	54	162	50	53 (53)	40 (40)	40	14	221 (221)	M6 (M6)	M6	66	12	13	6	42
50	70	—	—	12	100	150	180	161	24 (25)	16	82	11	7	54	181	63	56 (56)	50 (50)	40	14	251 (251)	M8 (M8)	M6	66	14	13	6	48
60	70	—	—	16	120	165	195	193	28 (30)	19	110	11	8.5	74	221	80	67.5 (67.5)	60 (60)	40	17	293 (293)	M10 (M10)	M6	94	15	15	8	61
80	85	—	—	21	135	185	230	218	38 (40)	24	156	14	—	114	276	100	105	80	50	20	348	M10 (M10)	M8	136	20	18	10	76
100	130	—	—	17	173	240	295	284.5	48 (50)	28	156	18	—	114	345	125	129	110	60	20	454	M12 (M12)	M8	136	22	17	10	95



IEC	AMP../1												ACP../1					
	32		40		50		60		80		100		32	40	50	60	80	100
	Y	cMP	Y	cMP	Y	cMP	Y	cMP	Y	cMP	Y	cMP	cCP					
B5	120	92	140	125	140	132	160	159	200	199	250	236	59	86	93	115	142	189
	140	92	160	125	160	132	200	174	250	209.5	300	236						
	160	92	200	145	200	152	250	184	300	230	350	300.5						
	200	102	250	155	250	162	300	208	350	260	400	305.5						
B14	90•	92	120	145	120	152	120	174.5	—	—	200	236						
	105•	92	140	145	140	152	140	174.5	—	—	—	—						
	120	102	160	155	160	162	160	184	—	—	—	—						
	—	—	—	—	—	—	200	208	—	—	—	—						

N.B.
 La configuration standard de la bride de fixation moteur prévoit 4 trous à 45° (exemple x: voir par. 1.3).
 Pour les brides marquées d'un symbole (*), les trous de fixation moteur sont disposés en parcours croisé (exemple +). Il s'avère donc nécessaire d'évaluer l'encombrement de la plaque à bornes du moteur qui sera installée car elle sera orientée à 45° par rapport aux axes. Pour le choix de la position de la plaque à bornes par rapport aux axes, se référer au schéma suivant (où la position 5 est celle standard) :

Nota:
 La configuración estándar de la brida toma motor prevé 4 agujeros a 45° (ejemplo x: consultar párr. 1.3).
 Para las bridas marcadas con el símbolo (*) los agujeros para la fijación al motor están dispuestos en cruz (ejemplo +). Por lo tanto, se recomienda evaluar las dimensiones de la caja de bornes del motor que será instalada porque deberá encontrarse orientada a 45° respecto a los ejes. Para la elección de la posición de la caja de bornes respecto a los ejes, consultar el siguiente esquema (en el cual la posición 5 es la estándar):

OBS.
 A configuração standard da flange de conexão ao motor prevê 4 furos de 45° (exemplo x: veja par. 1.3).
 Para as flanges marcadas com (*) os furos para fixagem ao motor são em cruz (exemplo +). Portanto é oportuno calcular o espaço do terminal conector do motor que será instalado, pois esta deve encontrar-se a 45° em relação aos eixos. Para a escolha da posição da sua posição em relação aos eixos veja o esquema seguinte (onde a posição 5 é a standard):

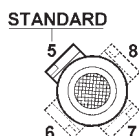

Les dimensions cMP se réfèrent aux combinaisons arbre/bride B5 et B14 standard. Pour les dimensions relatives aux combinaisons arbre/bride sur demande, contacter notre Service Technique.

Las dimensiones cMP se refieren a las combinaciones eje/brida B5 y B14, estándar. Para las dimensiones relativas a combinaciones eje/brida sobre pedido, contactar nuestro servicio técnico.

As dimensões cMP referem-se às combinações eixo/flange B5 e B14, standard. Para dimensões sob encomenda de combinações eixo/flange, contacte o nos. serviço técnico.



1.8 Dimension

1.8 Dimensiones

1.8 Dimensões



Dimensions réducteurs
Dimensiones reductoros
Dimensões redutores

AM/1 - AR/1 - AC/1

ARF (32)

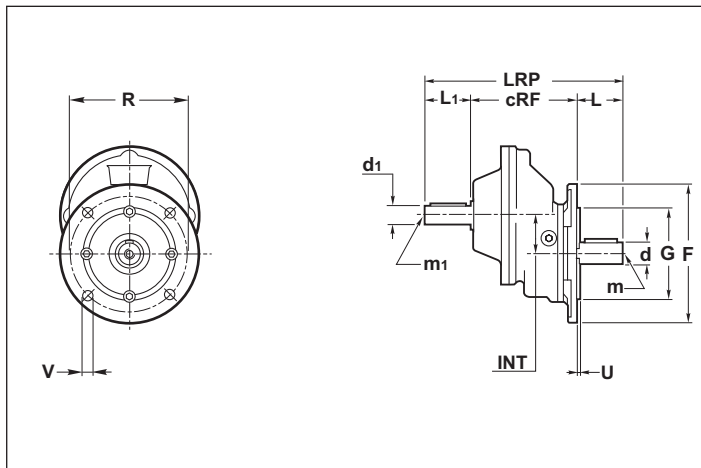

ARF (40 - 100)

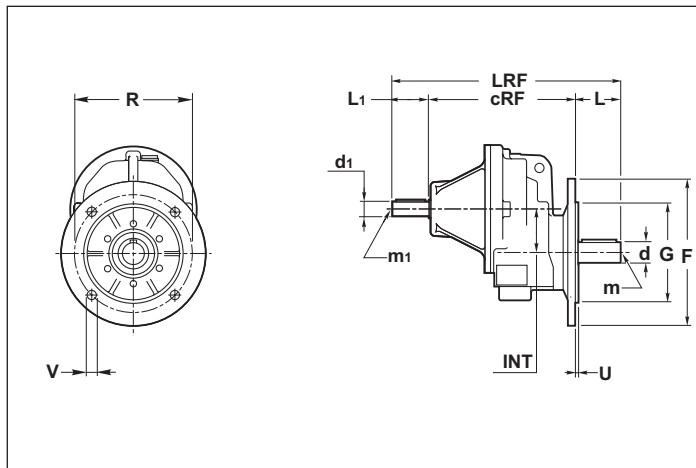

ACF (32)

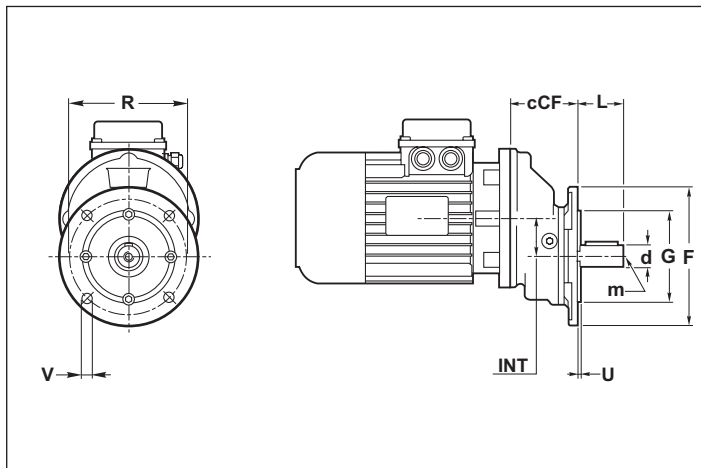

ACF (40 - 100)

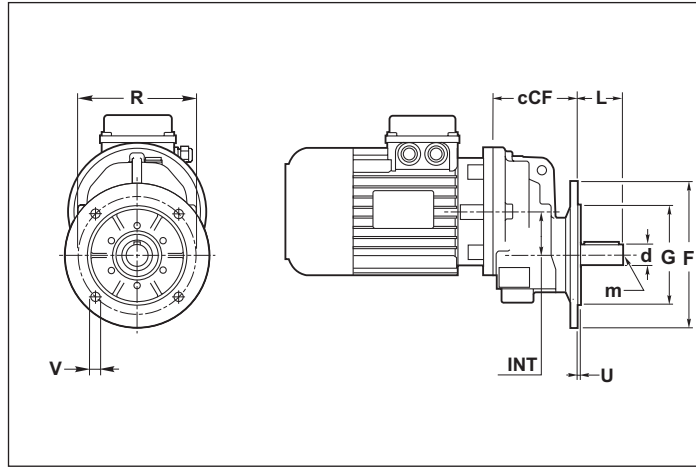

AMF (32)

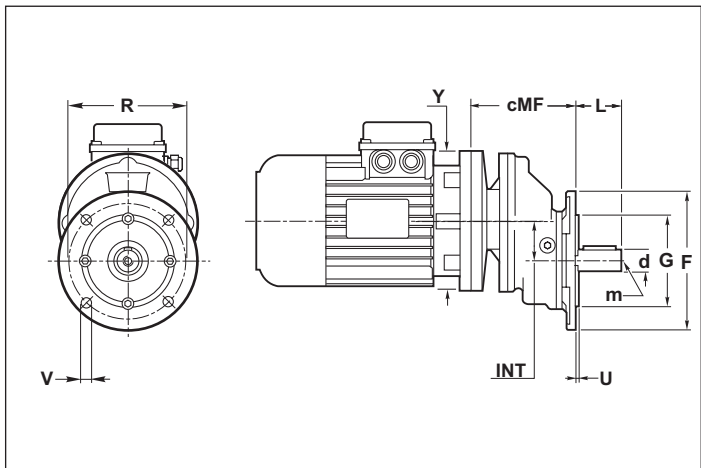

AMF (40 - 100)

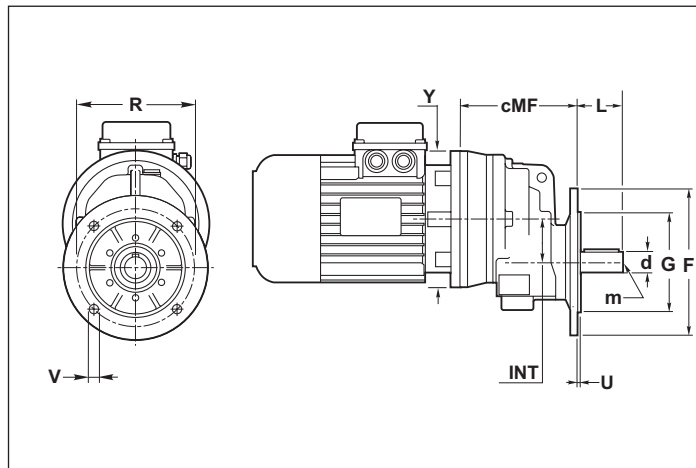



1.8 Dimension

1.8 Dimensiones

1.8 Dimensões

AM AC AR	cRF	d h6	d ₁ j6	L	L ₁	LRF	m	m ₁	INT
32	92	19 (14)	16	30 (40)	40	172 (162)	M6 (M6)	M6	33
40	141	19 (20)	16	40 (40)	40	221 (221)	M6 (M6)	M6	42
50	161	24 (25)	16	50 (50)	40	251 (251)	M8 (M8)	M6	48
60	193	28 (30)	19	60 (60)	40	293 (193)	M10 (M10)	M6	61
80	218	38 (40)	24	80	50	248	M10 (M10)	M8	76
100	284.5	48 (50)	28	110	60	454	M12 (M12)	M8	95

	32			40				50				60			80		100	
	F1	F2	F3	F1	F2	F3	F4	F1	F2	F3	F4	F1	F2	F3	F1	F2	F1	F2
F	120	140	160	120	140	160	200	120	140	160	200	160	200	250	250	300	250	300
G (g6)	80	95	110	80	95	110	130	80	95	110	130	110	130	180	180	230	180	230
R	100	115	130	100	115	130	165	100	115	130	165	130	165	215	215	265	215	265
V	9	9	10	9	9	10	13	9	9	10	13	10	13	15	15	15	15	15
U	3	3.5	3.5	3	3.5	3.5	3.5	3	3.5	3.5	3.5	3	3.5	3.5	4	4	4	4

IEC	AMF../1												ACF../1					
	32		40		50		60		80		100		32	40	50	60	80	100
	Y	cMF	Y	cMF	Y	cMF	Y	cMF	Y	cMF	Y	cMF	cCF					
B5	120	92	140	125	140	132	160	159	200	199	250	236	59	86	93	115	142	189
	140	92	160	125	160	132	200	174	250	209.5	300	236						
	160	92	200	145	200	152	250	184	300	230.5	350	300.5						
	200	102	250	155	250	162	300	208	350	260	400	305.5						
B14	90•	92	120	145	120	152	120	174.5	—	—	200	236						
	105•	92	140	145	140	152	140	174.5	—	—	—	—						
	120	102	160	155	160	162	160	184	—	—	—	—						
	—	—	—	—	—	—	200	208	—	—	—	—						

N.B.
La configuration standard de la bride de fixation moteur prévoit 4 trous à 45° (exemple x: voir par. 1.3).
Pour les brides marquées d'un symbole (•), les trous de fixation moteur sont disposés en parcours croisé (exemple +). Il s'avère donc nécessaire d'évaluer l'encombrement de la plaque à bornes du moteur qui sera installée car elle sera orientée à 45° par rapport aux axes. Pour le choix de la position de la plaque à bornes par rapport aux axes, se référer au schéma suivant (où la position 5 est celle standard) :

Nota:
La configuración estándar de la brida toma motor prevé 4 agujeros a 45° (ejemplo x: consultar párr. 1.3).
Para las bridas marcadas con el símbolo (•) los agujeros para la fijación al motor están dispuestos en cruz (ejemplo +). Por lo tanto, se recomienda evaluar las dimensiones de la caja de bornes del motor que será instalada porque deberá encontrarse orientada a 45° respecto a los ejes. Para la elección de la posición de la caja de bornes respecto a los ejes, consultar el siguiente esquema (en el cual la posición 5 es la estándar):

OBS.
A configuração standard da flange de conexão ao motor prevê 4 furos de 45° (exemplo x: veja par. 1.3).
Para as flanges marcadas com (•) os furos para fixagem ao motor são em cruz (exemplo +). Portanto é oportuno calcular o espaço do terminal conector do motor que será instalado, pois esta deve encontrar-se a 45° em relação aos eixos. Para a escolha da posição da sua posição em relação aos eixos veja o esquema seguinte (onde a posição 5 é a standard):

STANDARD

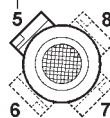

Les dimensions cMF se réfèrent aux combinaisons arbre/bride B5 et B14 standard. Pour les dimensions relatives aux combinaisons arbre/bride sur demande, contacter notre Service Technique.

Las dimensiones cMF se refieren a las combinaciones eje/brida B5 y B14, estándar. Para las dimensiones relativas a combinaciones eje/brida sobre pedido, contactar nuestro servicio técnico.

As dimensões cMF referem-se às combinações eixo/flange B5 e B14, standard. Para dimensões sob encomenda de combinações eixo/flange, contacte o nos. serviço técnico.



1.8 Dimensions

1.8 Dimensiones

1.8 Dimensões



Dimensions réducteurs
Dimensiones reductoros
Dimensões redutores

AM/2-3 - AR/2-3 - AC/2-3

AM (25)

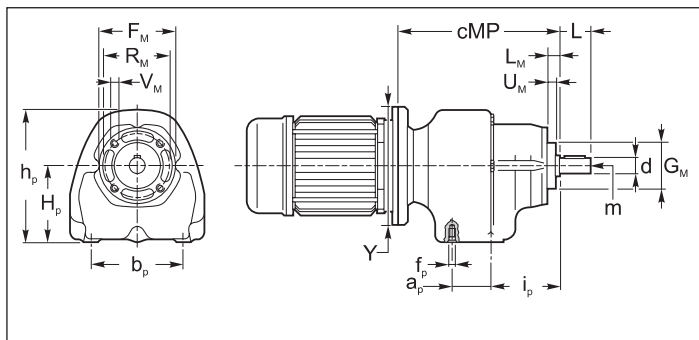

AC (25)

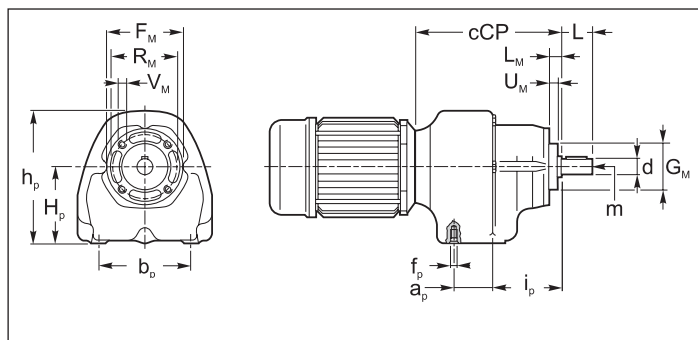

AMP (25)

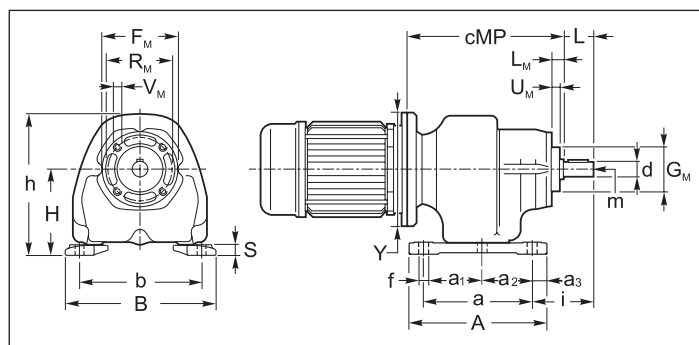

ACP (25)

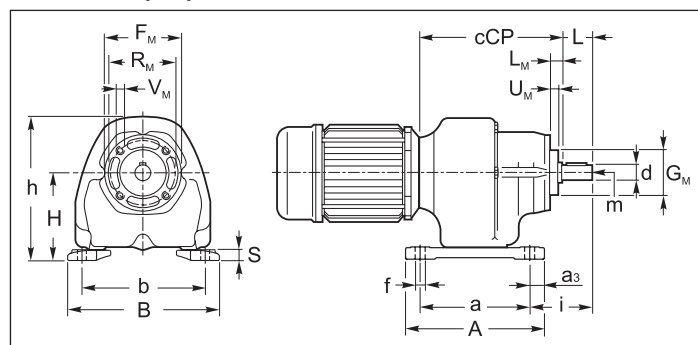

AM (35 - 41 - 45)

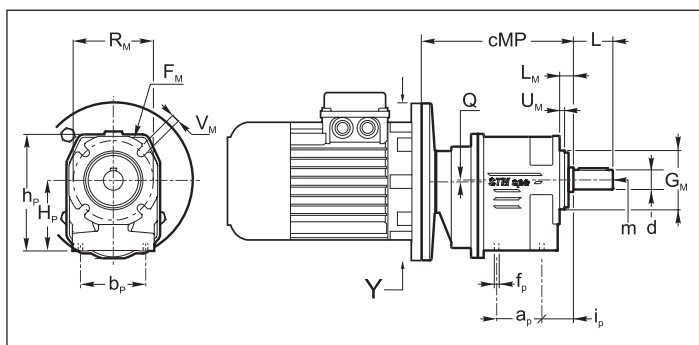

AMP (35 - 45) - AMP1 - AMP2 (41)

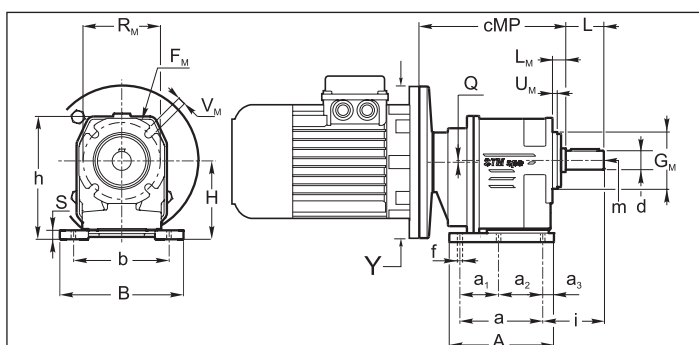



1.8 Dimension

1.8 Dimensiones

1.8 Dimensões

AM AC	a	a ₁	a ₂	a ₃	A	b	B	d j6(A25)-h6	f	h	H	i	L	m	Q	S
25	71	—	—	9.5	90	90±1	111	11 (14)	6.5	103	63	47 (50)	22 (25)	M5	-	8
35	87 ±2	37 ±2	50 ±2	11.5 ±1	110	110	130	16 (19) (20)	8.5	132	85	48±1 (58) (58)	30 (40) (40)	M6 (M6) (M6)	-	9
41	P1	87 ±2	37 ±2	50 ±2	110	110	130	20 (19) (25)	8.5	135	85	59±1 (59) (69)	40 (40) (50)	M6 (M6) (M8)	/2-2 /3-8	9
	P2	85	—	—	105	110	130		9.5	130	80	58 (58) (68)				10
45	107.5±2	47.5±2	60±2	13.5 ±1	135	130	155	25 (24) (30)	11	154	100	69±1 (69) (79)	50 (50) (60)	M8 (M8) (M10)	/2-3 /3-9.5	11

	a _p	b _p	f _p	i _p	h _p	H _p	F _M	G _M (g6)	L _M	R _M	V _M	U _M
25	23	66	M6	49	95	55	55	33	9	46	M6	6
35	50	55	M8	20.5	122	75	95	60	11	80	8	5
41	50	67	M8	20.5	122	72	95	60	11	80	8	5
45	60	75	M8	22.5	142	88	111	70	12	85	8	5

	IEC	25		35		41		45		25	35	41	45
		Y	cMP	Y	cMP	Y	cMP	Y	cMP				
AMP../2	B5	120	116	—	—	140	151.5	160	171.5	93.5	—	—	—
		140	116	140	126.5	160	151.5	200 (IEC 80)	171.5				
				160	126.5	200	160	200 (IEC 90)	182.0				
				200	136.0	—	—	250	184.0				
	B14	80•	116	90•	126.5	90•	151.5	105•	171.5				
		90	116	105	126.5	105•	151.5	120	171.5				
				120	136.0	120	160	140	182.0				
						140	160	160	184.0				
AMP../3	B5	120	116	120	144.0	140	168	160	188				
		140	116	140	144.0	160	168	200	188				
				—	—								
				—	—								
	B14	80•	116	80•	144.0	90	168	105	188				
		90	116	90	144.0	105	168	120	188				
				—	—								
				—	—								

N.B.
La configuration standard de la bride de fixation moteur prévoit 4 trous à 45° (exemple x: voir par. 1.3).
Pour les brides marquées d'un symbole (*), les trous de fixation moteur sont disposés en parcours croisé (exemple +). Il s'avère donc nécessaire d'évaluer l'encombrement de la plaque à bornes du moteur qui sera installée car elle sera orientée à 45° par rapport aux axes. Pour le choix de la position de la plaque à bornes par rapport aux axes, se référer au schéma suivant (où la position 5 est celle standard) :

Nota:
La configuración estándar de la brida toma motor prevé 4 agujeros a 45° (ejemplo x: consultar párr. 1.3).
Para las bridas marcadas con el símbolo () los agujeros para la fijación al motor están dispuestos en cruz (ejemplo +). Por lo tanto, se recomienda evaluar las dimensiones de la caja de bornes del motor que será instalada porque deberá encontrarse orientada a 45° respecto a los ejes. Para la elección de la posición de la caja de bornes respecto a los ejes, consultar el siguiente esquema (en el cual la posición 5 es la estándar):*

OBS.
A configuração standard da flange de conexão ao motor prevê 4 furos de 45° (exemplo x: veja par. 1.3).
Para as flanges marcadas com (*) os furos para fixagem ao motor são em cruz (exemplo +). Portanto é oportuno calcular o espaço do terminal conector do motor que será instalado, pois esta deve encontrar-se a 45° em relação aos eixos. Para a escolha da posição da sua posição em relação aos eixos veja o esquema seguinte (onde a posição 5 é a standard):

STANDARD

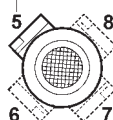

Les dimensions cMP se réfèrent aux combinaisons arbre/bride B5 et B14 standard. Pour les dimensions relatives aux combinaisons arbre/bride sur demande, contacter notre Service Technique.

Las dimensiones cMP se refieren a las combinaciones eje/brida B5 y B14, estándar. Para las dimensiones relativas a combinaciones eje/brida sobre pedido, contactar nuestro servicio técnico.

As dimensões cMP referem-se às combinações eixo/flange B5 e B14, standard. Para dimensões sob encomenda de combinações eixo/flange, contacte o nos. serviço técnico.



Dimensions réducteurs
Dimensiones reductoros
Dimensões redutores

AM/2-3 - AR/2-3 - AC/2-3

AMF (25)

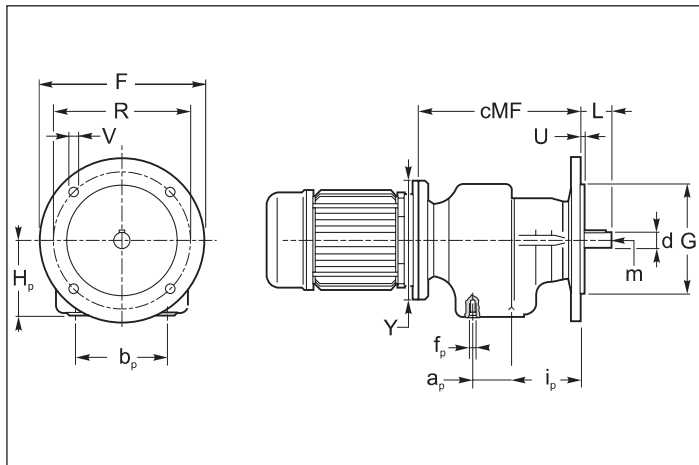

ACF (25)

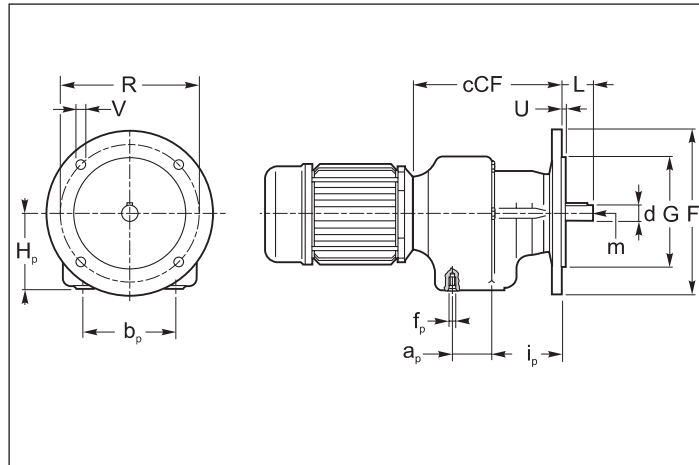

AMF (35 - 41 - 45)

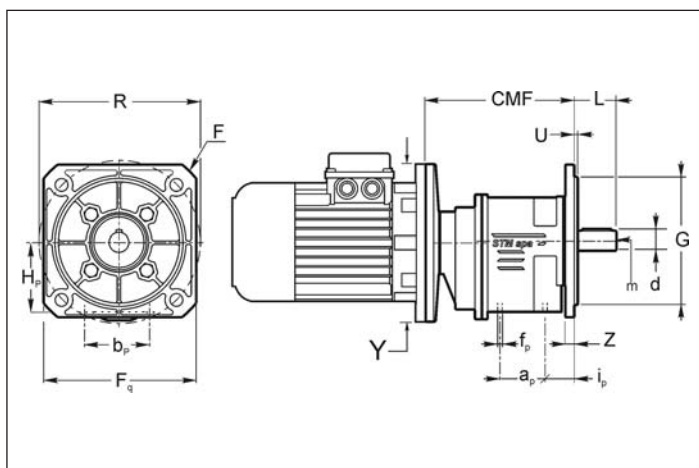



1.8 Dimension

1.8 Dimensiones

1.8 Dimensões

AM AC	ap	bp	fp	ip	Hp	d j6(A25)-h6	f	L	m	Q	S
25	23	66	M6	49	55	11 (14)	6.5	22 (25)	M5	-	8
35	50	55	M8	20.5	75	16 (19) (20)	8.5	30 (40) (40)	M6 (M6) (M6)	-	9
41	50	67	M8	20.5	72	20 (19) (25)	9.5	40 (40) (50)	M6 (M6) (M8)	/2-2 /3-8	10
45	60	75	M8	22.5	88	25 (24) (30)	11	50 (50) (60)	M8 (M8) (M10)	/2-3 /3-9.5	11

	AMF - ACF									
	25		35			41			45	
	F1	F2	F1	F2	F3	F1	F2	F3	F1	F2
F	105	120	140	160	200	140	160	200	160	200
F _Q	—	—	110	120	150	110	120	150	120	160
G(g6)	70	80	95	110	130	95	110	130	110	130
R	85	100	115	130	165	115	130	165	130	165
V	7	7	9	9	13	9	9	13	9	13
U	3	3	3.5	3.5	3.5	3.5	3.5	3.5	3.5	3.5

	IEC	25		35		41		45		25	35	41	45
		Y	cMF	Y	cMF	Y	cMF	Y	cMF				
AMF../2	B5	120	116	—	—	140	151.5	160	171.5	93.5	—	—	—
		140	116	140	126.5	160	151.5	200 (IEC 80)	171.5				
				160	126.5	200	160	200 (IEC 90)	182.0				
				200	136.0	—	—	250	184.0				
	B14	80•	116	90•	126.5	90•	151.5	105•	171.5				
		90	116	105	126.5	105•	151.5	120	171.5				
			120	136.0	120	160	140	182.0					
AMF../3	B5	120	116	120	144.0	140	168	160	188.0				
		140	116	140	144.0	160	168	200	188.0				
				—	—								
	B14	80•	116	80•	144.0	90	168	105	188.0				
		90	116	90	144.0	105	168	120	188.0				
				—	—								

N.B.
La configuration standard de la bride de fixation moteur prévoit 4 trous à 45° (exemple x: voir par. 1.3).

Pour les brides marquées d'un symbole (+), les trous de fixation moteur sont disposés en parcours croisé (exemple +). Il s'avère donc nécessaire d'évaluer l'encombrement de la plaque à bornes du moteur qui sera installée car elle sera orientée à 45° par rapport aux axes. Pour le choix de la position de la plaque à bornes par rapport aux axes, se référer au schéma suivant (où la position 5 est celle standard) :

Nota:
La configuración estándar de la brida toma motor prevé 4 agujeros a 45° (ejemplo x: consultar párr. 1.3).

Para las bridas marcadas con el símbolo (+) los agujeros para la fijación al motor están dispuestos en cruz (ejemplo +). Por lo tanto, se recomienda evaluar las dimensiones de la caja de bornes del motor que será instalada porque deberá encontrarse orientada a 45° respecto a los ejes. Para la elección de la posición de la caja de bornes respecto a los ejes, consultar el siguiente esquema (en el cual la posición 5 es la estándar):

STANDARD

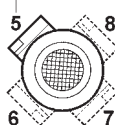

Les dimensions cMF se réfèrent aux combinaisons arbre/bride B5 et B14 standard.

Pour les dimensions relatives aux combinaisons arbre/bride sur demande, contacter notre Service Technique.

Las dimensiones cMF se refieren a las combinaciones eje/brida B5 y B14, estándar.

Para las dimensiones relativas a combinaciones eje/brida sobre pedido, contactar nuestro servicio técnico.

OBS.
A configuração standard da flange de conexão ao motor prevê 4 furos de 45° (exemplo x: veja par. 1.3).

Para as flanges marcadas com (+) os furos para fixagem ao motor são em cruz (exemplo +). Portanto é oportuno calcular o espaço do terminal conector do motor que será instalado, pois esta deve encontrar-se a 45° em relação aos eixos. Para a escolha da posição da sua posição em relação aos eixos veja o esquema seguinte (onde a posição 5 é a standard):

As dimensões cMF referem-se às combinações eixo/flange B5 e B14, standard.

Para dimensões sob encomenda de combinações eixo/flange, contacte o nos. serviço técnico.



1.8 Dimension

1.8 Dimensiones

1.8 Dimensões



Dimensions réducteurs
Dimensiones reductoros
Dimensões redutores

AM/2-3 - AR/2-3 - AC/2-3

AMP/F.. (25)

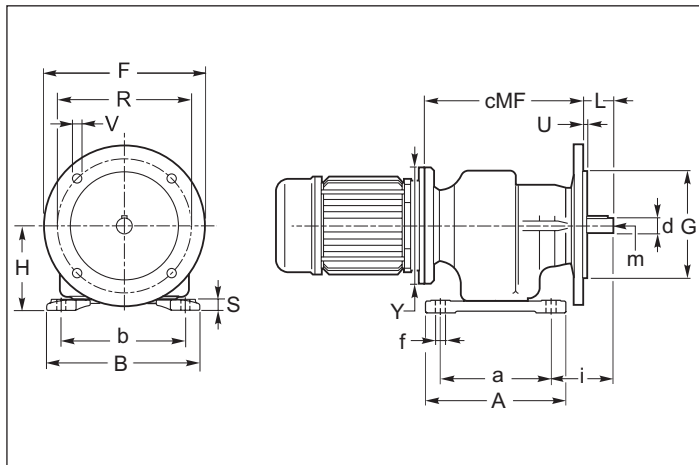

ACP/F.. (25)

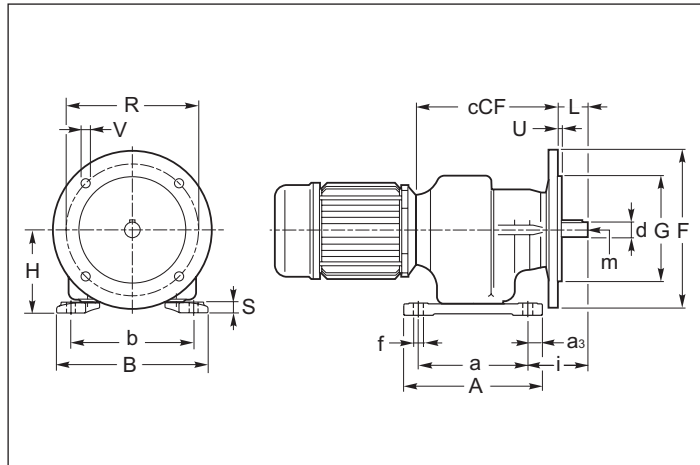

AMP/F. (35-45) AMP1/F.-AMP2/F. (41)

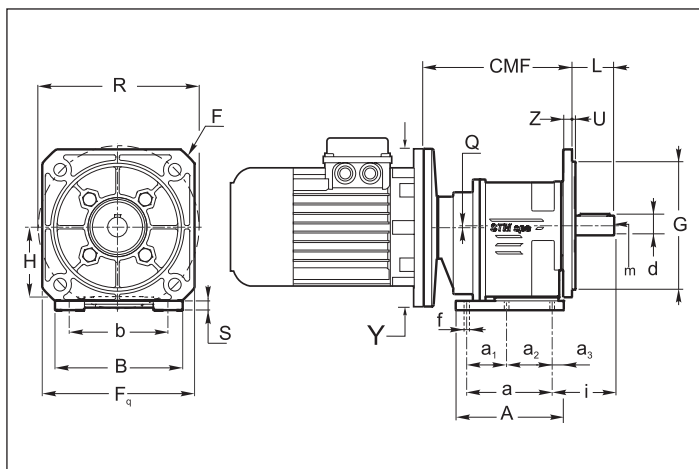



1.8 Dimension

1.8 Dimensiones

1.8 Dimensões

AM AC	a	a ₁	a ₂	a ₃	A	b	B	d j6(A25)-h6	f	h	H	i	L	m	Q	S
25	71	—	—	9.5	90	90±1	111	11 (14)	6.5	103	63	47 (50)	22 (25)	M5	-	8
35	87 ±2	37 ±2	50 ±2	11.5 ±1	110	110	130	16 (19) (20)	8.5	132	85	48±1 (58) (58)	30 (40) (40)	M6 (M6) (M6)	-	9
41	P1	87 ±2	37 ±2	50 ±2	110	110	130	20 (19) (25)	8.5	135	85	59±1 (59) (69)	40 (40) (50)	M6 (M6) (M8)	/2-2 /3-8	9
	P2	85	—	—	105	110	130		9.5	130	80	58 (58) (68)				10
45	107.5±2	47.5±2	60±2	13.5 ±1	135	130	155	25 (24) (30)	11	154	100	69±1 (69) (79)	50 (50) (60)	M8 (M8) (M10)	/2-3 /3-9.5	11

	AMP/F. - ACP/F.									
	25		35			41			45	
	F1	F2	F1	F2	F3	F1	F2	F3	F1	F2
F	105	120	140	160	200	140	160	200	160	200
F _q	—	—	110	120	150	110	120	150	120	160
G(g6)	70	80	95	110	130	95	110	130	110	130
R	85	100	115	130	165	115	130	165	130	165
V	7	7	9	9	13	9	9	13	9	13
U	3	3	3.5	3.5	3.5	3.5	3.5	3.5	3.5	3.5

	IEC	25		35		41		45		25	35	41	45
		Y	cMF	Y	cMF	Y	cMF	Y	cMF				
		cCP											
AMP/F../2	B5	120	116	—	—	140	151.5	160	171.5	93.5	—	—	—
		140	116	140	126.5	160	151.5	200 (IEC 80)	171.5				
				160	126.5	200	160	200 (IEC 90)	182.0				
				200	136.0	—	—	250	184.0				
	B14	80•	116	90•	126.5	90•	151.5	105•	171.5				
		90	116	105	126.5	105•	151.5	120	171.5				
AMP/F../3	B5			120	144.0	140	168	160	188.0				
				140	144.0	160	168	200	188.0				
				—	—								
				—	—								
	B14	80•	116	80•	144.0	90	168	105	188.0				
		90	116	90	144.0	105	168	120	188.0				
				—	—								
				—	—								

N.B.
La configuration standard de la bride de fixation moteur prévoit 4 trous à 45° (exemple x: voir par. 1.3).

Pour les brides marquées d'un symbole (*), les trous de fixation moteur sont disposés en parcours croisé (exemple +). Il s'avère donc nécessaire d'évaluer l'encombrement de la plaque à bornes du moteur qui sera installée car elle sera orientée à 45° par rapport aux axes. Pour le choix de la position de la plaque à bornes par rapport aux axes, se référer au schéma suivant (où la position 5 est celle standard) :

Nota:
La configuración estándar de la brida toma motor prevé 4 agujeros a 45° (ejemplo x: consultar párr. 1.3).

Para las bridas marcadas con el símbolo (*) los agujeros para la fijación al motor están dispuestos en cruz (ejemplo +). Por lo tanto, se recomienda evaluar las dimensiones de la caja de bornes del motor que será instalada porque deberá encontrarse orientada a 45° respecto a los ejes. Para la elección de la posición de la caja de bornes respecto a los ejes, consultar el siguiente esquema (en el cual la posición 5 es la estándar):

STANDARD

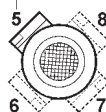

Les dimensions cMF se réfèrent aux combinaisons arbre/bride B5 et B14 standard.

Pour les dimensions relatives aux combinaisons arbre/bride sur demande, contacter notre Service Technique.

The cMF dimensions refer to the standard B5 and B14 shaft/flange combinations. As far as the dimensions of shaft/flange combinations on request are concerned, please contact our technical department.

HINWEIS.

In der Standardkonfiguration sind die 4 Flanschbohrungen im 45°-Winkel zu den Achsen angeordnet (wie ein x: siehe Kapitel 1.3).

Bei B14-Flanschen, die mit (*) gekennzeichnet sind, sind die Bohrungen auf den Achsen angeordnet (wie ein +). Es sollte deshalb der Platzbedarf des Motorklemmenkastens beachtet werden, da er sich in 45°-Position zu den Achsen befinden wird. Die Lage des Klemmenkastens des Motors wählen Sie bitte anhand der folgenden Skizze (Pos.5 ist Standardposition):

Die Maße cMF beziehen sich auf die Kombinationen Welle/Flansch B5 und B14 Standard. Hinsichtlich der Maße von Kombinationen Welle/Flansch auf Anfrage wenden Sie sich bitte an unseren technischen Kundendienst.



1.8 Dimension

1.8 Dimensiones

1.8 Dimensões



Dimensions réducteurs
Dimensiones reductoros
Dimensões redutores

AM/2-3 - AR/2-3 - AC/2-3

AMP (50-55-60-70-80-90-100-110-120-140)

55-70-90-110-140

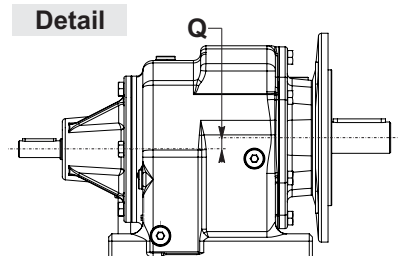
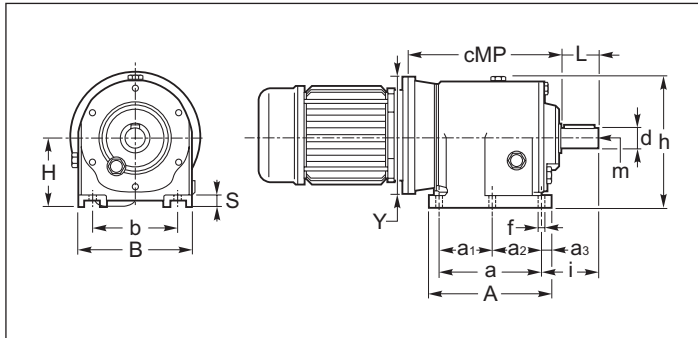

ARP (50-55-60-70-80-90-100-110-120-140)

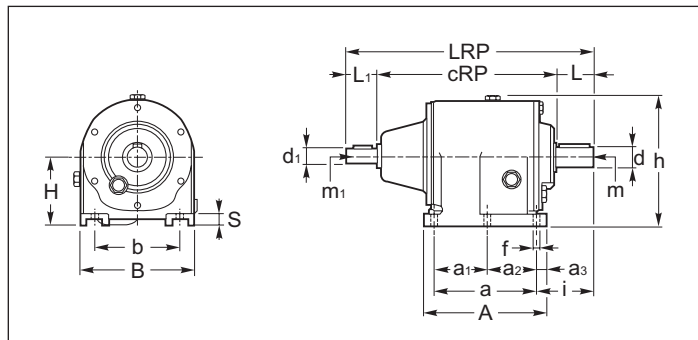

ACP (50-55-60-70-80-90)

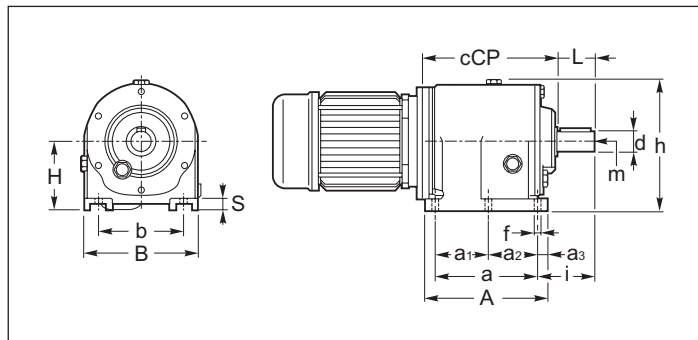



1.8 Dimension

1.8 Dimensiones

1.8 Dimensões

AM AC AR	a	a ₁	a ₂	a ₃	A	b	B	cRP	d h6	d ₁ j6	f	h	H	i	L	L ₁	LRP	m	m ₁	Q	S
50	130			12.5	155	110	145	227	25 (24) (30)	16	9.5	170	90	75 (75) (85)	50 (50) (60)	40	317 (317) (327)	M8 (M8) (M10)	M6	—	15
55	165			15	195	135	180	/2 238.5 /3 257.0	30	16	14	203	115	90	60	40	/2 338.5 /3 357.0	M10	M6	11	23
60	165			15	195	135	185	269	30 (28) (35)	19	14	210	115	90 (90) (100)	60 (60) (70)	40	369 (369) (379)	M10 (M10) (M10)	M6	—	20
70	195			20	235	150	210	/2 266.5 /3 288.5	35	19	14	233	130	100	70	40	/2 376.5 /3 398.5	M10	M6	13.5	23
80	205			20	245	170	230	309.5	40 (38)	24	20	265	140	115 (115)	80 (80)	50	440 (440)	M10 (M10)	M8	—	25
90	260			25	310	215	280	/2 332.5 /3 347.5	50 (48)	24	20	307	195	140	100	50	/2 482.5 /3 497.5	M12 (M12)	M8	39.5	35
100	260			21	306	215	290	395	50 (48)	28	20	322	180	140 (140)	100 (100)	60	555 (555)	M12 (M12)	M8	—	35
110	310			25	360	250	320	422	60	28	23	351	225	160	120	60	602	M12	M8	36	35
120	310			27.5	365	250	350	460	60	38	23	415	225	160	120	80	660	M12	M10	—	45
140	370			35	440	290	400	/2 458.5 /3 508.0	70	38	27	423	270	185	140	110	/2 708.5 /3 758.0	M16	M10	41.4	60

AMP	IEC	50		55		60		70		80		90		100		110		120		140	
		Y	cMP	Y	cMP	Y	cMP	Y	cMP	Y	cMP	Y	cMP	Y	cMP	Y	cMP	Y	cMP	Y	cMP
AMP../2	B5	140	198	160	233.5	160	235	200	284.5	200	291	250	313	250	347.4	250	374	250	409	300	465
		160	198	200	233.5	200	250	250	284.5	250	303	300	345	300	347.4	300	374	300	409	350	474
		200	218	250	244	250	260	300	284.5	300	322	350	364	350	411.4	350	438	350	451.5	400	479
		250	228	—	—	300	284	—	—	350	352	—	—	400	416.4	400	443	400	456.5	450	519
	B14	120	218	120	233.5	120	250	200	284.5	—	—	—	—	200	347.4	200	374	200	409	—	—
		140	218	140	233.5	140	250	—	—	—	—	—	—	—	—	—	—	—	—	—	—
		160	228	160	244	160	260	160	262	—	—	—	—	—	—	—	—	—	—	—	—
		—	—	—	—	200	284	—	—	—	—	—	—	—	—	—	—	—	—	—	—
AMP../3	B5	140	198	140	228	160	235	160	254.5	200	291	200	338.5	200	340.4	200	367	200	392	250	457
		160	198	160	228	200	250	200	269.5	250	301	250	331	250	350.4	250	377	250	410	300	457
		200	218	200	238	250	260	250	279.5	—	—	—	—	300	370.4	300	397	300	421	350	499.5
		—	—	—	—	—	—	—	—	—	—	—	—	—	—	—	—	—	—	400	504.5
	B14	120	218	120	238	120	250	120	269.5	—	—	—	—	—	—	—	—	—	—	200	457
		140	218	140	238	140	250	140	269.5	—	—	—	—	—	—	—	—	—	—	—	—
		—	—	—	—	160	260	160	279.5	—	—	—	—	—	—	—	—	—	—	—	—
		—	—	—	—	—	—	—	—	—	—	—	—	—	—	—	—	—	—	—	—

ACP	50	55	60	70	80	90
	cCF					
ACP../2	159	—	191	—	234	—
ACP../3	159	189	191	210.5	234	271

Les dimensions cMF se réfèrent aux combinaisons arbre/bride B5 et B14 standard. Pour les dimensions relatives aux combinaisons arbre/bride sur demande, contacter notre Service Technique.

Las dimensiones cMF se refieren a las combinaciones eje/brida B5 y B14, estándar. Para las dimensiones relativas a combinaciones eje/brida sobre pedido, contactar nuestro servicio técnico.

As dimensões cMF referem-se às combinações eixo/flange B5 e B14, standard. Para dimensões sob encomenda de combinações eixo/flange, contacte o nos. serviço técnico.



1.8 Dimension

1.8 Dimensiones

1.8 Dimensões



Dimensions réducteurs
Dimensiones reductoros
Dimensões redutores

AM/2-3 - AR/2-3 - AC/2-3

AMF (50-55-60-70-80-90-100-110-120-140)

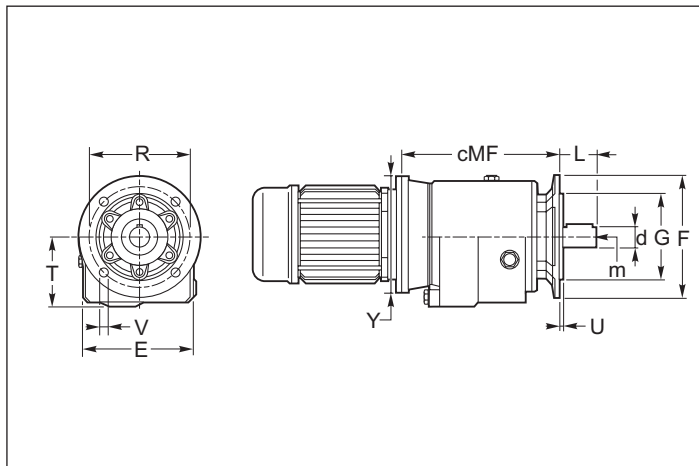

55-70-90-110-140

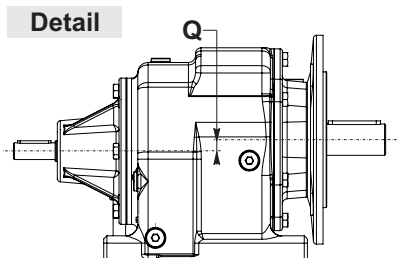

ARF (50-55-60-70-80-90-100-110-120-140)

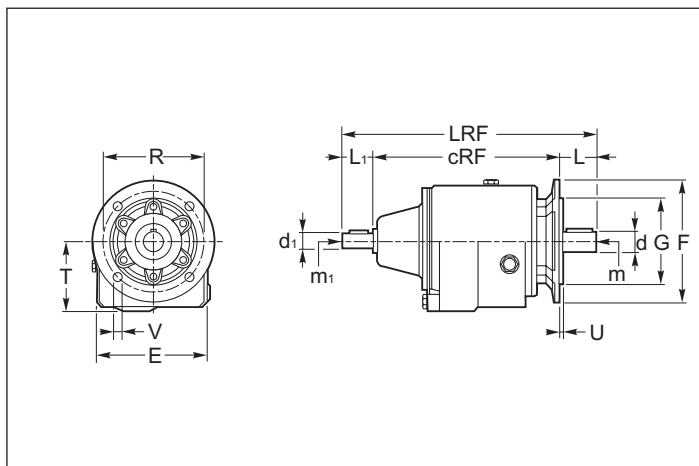

ACF (50-55-60-70-80-90)

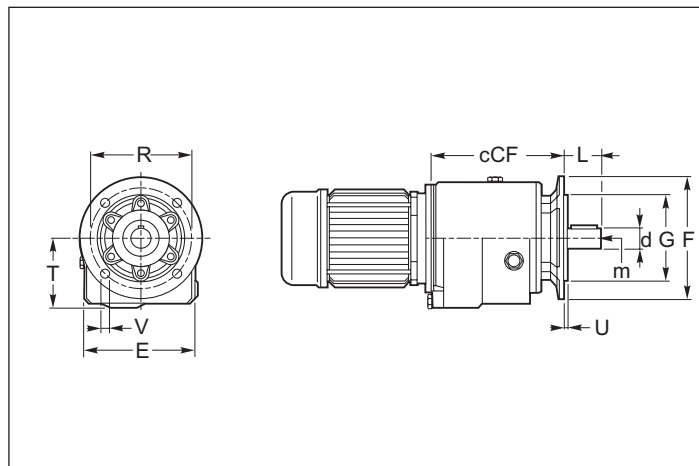



1.8 Dimension

1.8 Dimensiones

1.8 Dimensões

AM AC AR	cRF	d h6	d ₁ j6	E	L	L ₁	LRF	m	m ₁	Q	T
50	235	25 (24) (30)	16	145	50 (50) (60)	40	325 (325) (335)	M8 (M8) (M10)	M6	—	89.5
55	/2 238 /3 256.5	30	16	186	60	40	/2 338 /3 356.5	M10	M6	11	114
60	280	30 (28) (35)	19	185	60 (60) (70)	40	380 (380) (390)	M10 (M10) (M10)	M6	—	114
70	/2 266.5 /3 288.5	35	19	212	70	40	/2 376.5 /3 398.5	M10	M6	13.5	129
80	317	40 (38)	24	230	80 (80)	50	447 (447)	M10 (M10)	M8	—	139
90	/2 332.5 /3 347.5	50 (48)	24	264	100	50	/2 482.5 /3 497.5	M12 (M12)	M8	39.5	192.5
100	395	50 (48)	28	290	100 (100)	60	555 (555)	M12 (M12)	M8	—	178
110	422	60	28	314	120	60	602	M12	M8	36	222
120	491	60	38	350	120	80	691	M12	M10	—	225
140	/2 458.5 /3 508.0	70	38	414	140	110	/2 708.5 /3 758.0	M16	M10	41.4	322

		AMF.. - ACF..																																							
		50				55				60				70				80				90				100				110				120				140			
		F1	F2	F3	F4	F1	F2	F3	F4	F1	F2	F3	F4	F1	F2	F3	F4	F1	F2	F3	F4	F1	F2	F3	F4	F1	F2	F3	F4	F1	F2	F3	F4	F1	F2	F3	F4				
F		120	160	200	250	160	200	250	—	160	200	250	300	250	300	350	300	250	300	350	300	350	450	400	350	450	400	350	400	350	400	350	400	350	400	350	400				
F_Q		—	—	—	—	—	—	—	—	—	—	—	—	—	—	—	—	—	—	—	—	—	—	—	—	—	—	—	—	—	—	—	—	—	—	—	—				
G(g6)		80	110	130	180	110	130	180	110	130	180	180	230	180	230	230	250	230	250	250	350	350	300	250	350	350	300	250	350	300	250	300	350	300	350	300	350				
R		100	130	165	215	130	165	215	130	165	215	215	265	215	265	265	300	265	300	300	400	400	350	300	400	350	300	400	350	300	350	300	350	300	350	300	350				
V		9	10	13	15	10	13	15	10	13	15	15	15	15	15	15	19	15	19	19	19*	18	19	19*	18	19	19*	18	19	19*	19*	19*	19*	19*	19*	19*	19*				
U		3	3.5	3.5	4	3	3.5	3.5	3	3.5	3.5	4	4	4	4	4	5	4	5	5	5	5	5	5	5	5	5	5	5	5	5	5	5	5	5	5	5				

* 8 trous / orificios / furos

AMF	IEC	50		55		60		70		80		90		100		110		120		140				
		Y	cMF	Y	cMF	Y	cMF	Y	cMF	Y	cMF	Y	cMF	Y	cMF	Y	cMF	Y	cMF	Y	cMF			
AMF../2	B5	140	206	160	233.5	160	246	200	284.5	200	298	250	313	250	347.4	250	374	250	440	300	465			
		160	206	200	233.5	200	261	250	284.5	250	308	300	345	300	347.4	300	374	300	440	350	474			
		200	226	250	243.5	250	271	300	284.5	300	329	350	364	350	411.4	350	438	350	482.5	400	479			
		250	236	—	—	300	295	—	—	350	359	—	—	400	416.4	400	443	400	487.5	450	519			
	—																		450	496.5	550	519		
	B14	120	226	120	233.5	120	261	200	284.5	—				200	347.4	200	374	200	440	—				
		140	226	140	233.5	140	261	—	—	—				—	—	—	—	—	—	—				
		160	236	160	243.5	160	271	160	262	—				—	—	—	—	—	—	—				
—				200	295	—	—	—				—	—	—	—	—	—	—	—					
AMF../3	B5	140	206	140	228	160	246	160	254.5	200	298	200	331	200	340.4	200	367	200	423	250	457			
		160	206	160	228	200	261	200	269.5	250	308	250	338.5	250	350.4	250	377	250	445	300	457			
		200	226	200	238	250	271	250	279.5	—				300	370.4	300	397	300	452	350	499.5			
	—																		400	504.5	—	—		
	—																		450	513.5	—	—		
	B14	120	226	120	238	120	261	120	269.5	—				—	—	—	—	—	—	—	200	457		
		140	226	140	238	140	261	140	269.5	—				—	—	—	—	—	—	—	—			
		—				160	271	160	279.5	—				—	—	—	—	—	—	—	—			

ACF	50	55	60	70	80	90
	cCP					
ACF../2	167	—	202	—	241	—
ACF../3	167	189	202	210.5	241	271

Les dimensions cMF se réfèrent aux combinaisons arbre/bride B5 et B14 standard. Pour les dimensions relatives aux combinaisons arbre/bride sur demande, contacter notre Service Technique.

Las dimensiones cMF se refieren a las combinaciones eje/brida B5 y B14, estándar. Para las dimensiones relativas a combinaciones eje/brida sobre pedido, contactar nuestro servicio técnico.

As dimensões cMF referem-se às combinações eixo/flange B5 e B14, standard. Para dimensões sob encomenda de combinações eixo/flange, contacte o nos. serviço técnico.



1.8 Dimension

1.8 Dimensiones

1.8 Dimensões



Dimensions réducteurs
Dimensiones reductoros
Dimensões redutores

AM/2-3 - AR/2-3 - AC/2-3

AMP/F (50-55-60-70-80-90-110-120-140)

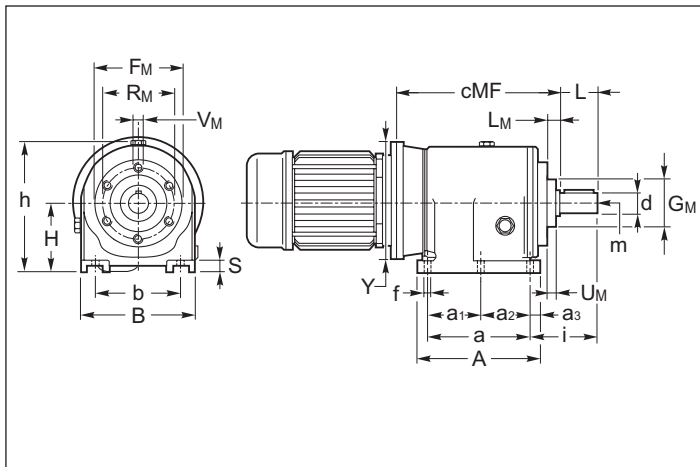

55-70-90-110-140

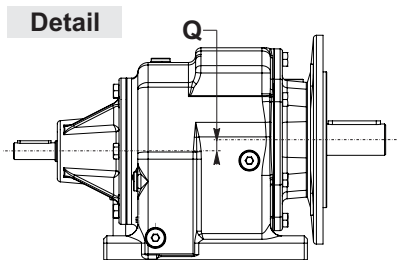

ARP/F (50-55-60-70-80-90-110-120-140)

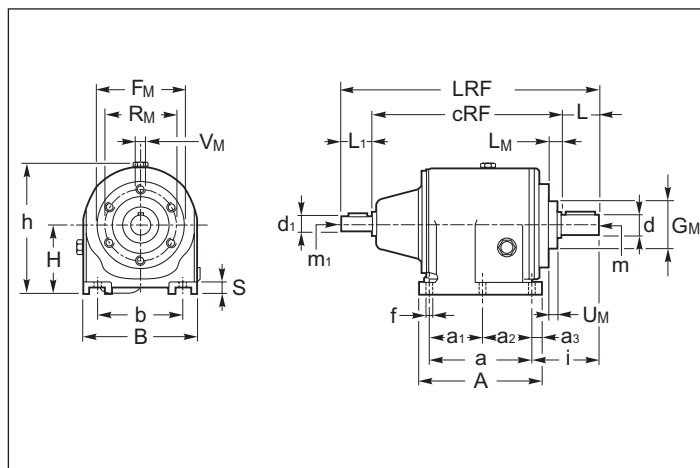

ACP/F (50-55-60-70-80-90)

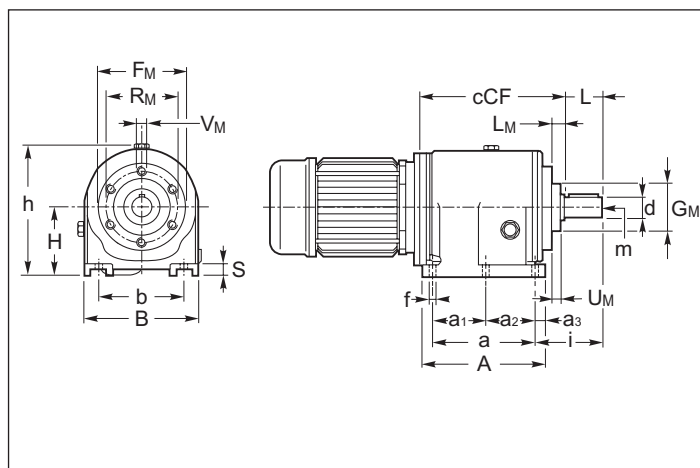



1.8 Dimension

1.8 Dimensiones

1.8 Dimensões

AM AC AR	a	a ₁	a ₂	a ₃	A	b	B	cRP	d h6	d ₁ j6	f	h	H	i	L	L ₁	LRF	m	m ₁	Q	S
50	130			12.5	155	110	145	235	25 (24) (30)	16	9.5	170	90	83 (83) (93)	50 (50) (60)	40	325 (325) (335)	M8 (M8) (M10)	M6	—	15
55	165			15	195	135	180	/2 238.5 /3 257.0	30	16	14	203	115	90	60	40	/2 338.5 /3 357.0	M10	M6	11	23
60	165			15	195	135	185	280	30 (28) (35)	19	14	210	115	101 (101) (111)	60 (60) (70)	40	380 (380) (390)	M10 (M10) (M10)	M6	—	20
70	195			20	235	150	210	/2 266.5 /3 288.5	35	19	14	233	130	100	70	40	/2 376.5 /3 398.5	M10	M6	13.5	23
80	205			20	245	170	230	317	40 (38)	24	20	265	140	123 (123)	80 (80)	50	447 (447)	M10 (M10)	M8	—	25
90	260			25	310	215	280	/2 332.5 /3 347.5	50 (48)	24	20	307	195	140	100	50	/2 482.5 /3 497.5	M12 (M12)	M8	39.5	35
110	310			25	360	250	320	422	60	28	23	351	225	160	120	60	602	M12	M8	36	35
120	310			27.5	365	250	350	491	60	38	23	415	225	191	120	80	691	M12	M10	—	45
140	370			35	440	290	400	/2 458.5 /3 508.0	70	38	27	423	270	185	140	110	/2 708.5 /3 758.0	M16	M10	41.4	60

	AMP/F. - ACP/F.								
	50	55	60	70	80	90	110	120	140
F _M	110	110	110	Look picture	156.9	155	Look picture	230	Look picture
G _M (g6)	74	74	74		114	110 (G6)		170	
L _M	16	16	16	20	20	23	31.5	26.5	45.5
R _M	94	94	94	Look picture	136	130	Look picture	200	Look picture
V _M	M8	M8	M8		M10	M10		M12	
U _M	7	6	6	7	13	10	10	18	22

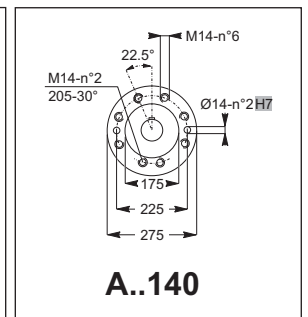
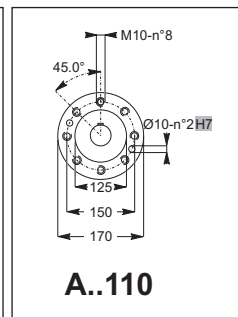
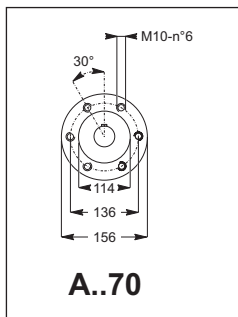

	IEC	50		55		60		70		80		90		100		110		120		140	
		Y	cMF	Y	cMF	Y	cMF	Y	cMF	Y	cMF	Y	cMP	Y	cMF	Y	cMF	Y	cMF	Y	cMF
AMP/F../2	B5	140	206	160	233.5	160	246	200	284.5	200	298	250	313	250	347.4	250	374	250	440	300	465
		160	206	200	233.5	200	261	250	284.5	250	308	300	345	300	347.4	300	374	300	440	350	474
		200	226	250	244	250	271	300	284.5	300	329	350	364	350	411.4	350	438	350	482.5	400	479
		250	236	—	—	300	295	—	—	350	359	—	—	400	416.4	400	443	400	487.5	450	519
	B14	120	226	120	233.5	120	261	200	284.5	—	—	—	—	200	347.4	200	374	200	440	—	—
		140	226	140	233.5	140	261	—	—	—	—	—	—	—	—	—	—	—	—	—	—
160		236	160	244	160	271	160	262	—	—	—	—	—	—	—	—	—	—	—	—	
AMP/F../3	B5	140	206	140	228	160	246	160	254.5	200	298	200	331	200	340.4	200	367	200	423	250	457
		160	206	160	228	200	261	200	269.5	250	308	250	338.5	250	350.4	250	377	250	445	300	457
		200	226	200	238	250	271	250	279.5	—	—	—	—	300	370.4	300	397	300	452	350	499.5
		—	—	—	—	—	—	—	—	—	—	—	—	—	—	—	—	—	—	400	504.5
	B14	120	226	120	238	120	261	120	269.5	—	—	—	—	—	—	—	—	—	—	—	—
		140	226	140	238	140	261	140	269.5	—	—	—	—	—	—	—	—	—	—	200	457
—	—	—	—	160	271	160	279.5	—	—	—	—	—	—	—	—	—	—	—	—	—	

ACP/F	50	55	60	70	80	90
	cCP					
ACP/F../2	167	—	202	—	241	—
ACP/F../3	167	189	202	210.5	241	271

Les dimensions cMP se réfèrent aux combinaisons arbre/bride B5 et B14 standard.
Pour les dimensions relatives aux combinaisons arbre/bride sur demande, contacter notre Service Technique.

Las dimensiones cMP se refieren a las combinaciones eje/brida B5 y B14, estándar.
Para las dimensiones relativas a combinaciones eje/brida sobre pedido, contactar nuestro servicio técnico.

As dimensões cMP referem-se às combinações eixo/flange B5 e B14, standard.
Para dimensões sob encomenda de combinações eixo/flange, contacte o nos. serviço técnico.



Dimensions réducteurs
Dimensiones reductoros
Dimensões redutores

AM/2-3 - AR/2-3 - AC/2-3

AMP/F1.. (50- 55-60-70-80-90-120-140)

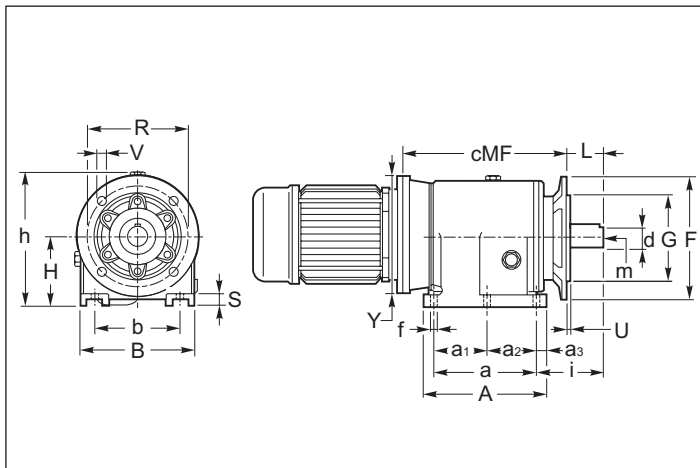

55-70-90-110-140

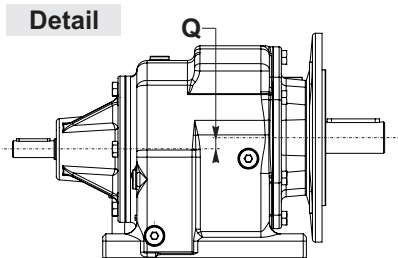

ARP/F1.. (50- 55-60-70-80-90-120-140)

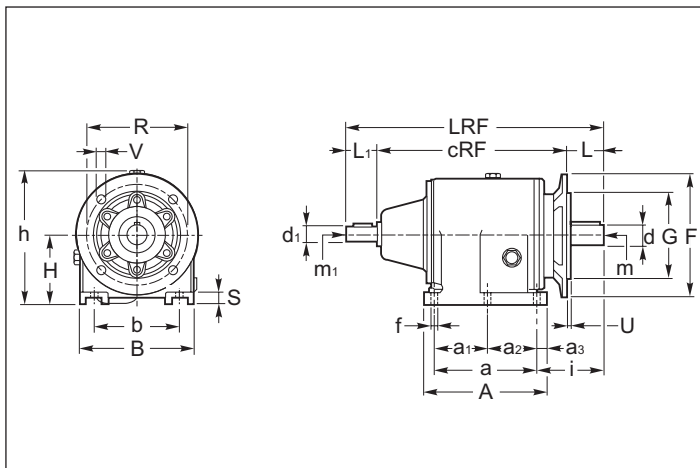

ACP/F1.. (50-55-60-70-80-90)

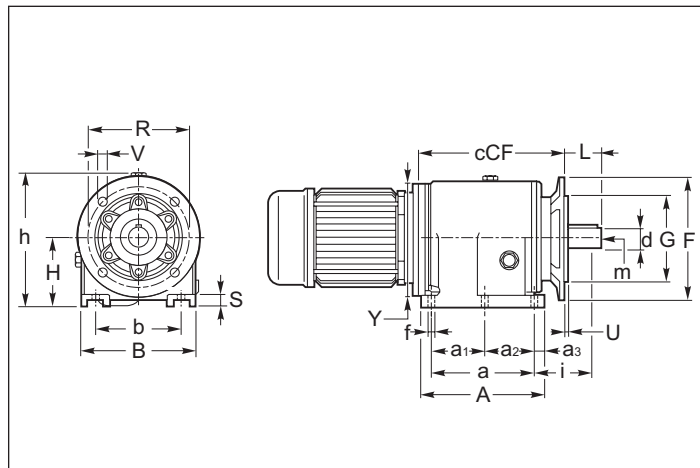



1.8 Dimension

1.8 Dimensiones

1.8 Dimensões

AM AC AR	a	a ₁	a ₂	a ₃	A	b	B	cRP	d h6	d ₁ j6	f	h	H	i	L	L ₁	LRF	m	m ₁	Q	S
50	130			12.5	155	110	145	235	25 (24) (30)	16	9.5	170	90	83 (83) (93)	50 (50) (60)	40	325 (325) (335)	M8 (M8) (M10)	M6	—	15
55	165			15	195	135	180	/2 238.5 /3 257.0	30	16	14	203	115	90	60	40	/2 338.5 /3 357.0	M10	M6	11	23
60	165			15	195	135	185	280	30 (28) (35)	19	14	210	115	101 (101) (111)	60 (60) (70)	40	380 (380) (390)	M10 (M10) (M10)	M6	—	20
70	195			20	235	150	210	/2 266.5 /3 288.5	35	19	14	233	130	100	70	40	/2 376.5 /3 398.5	M10	M6	13.5	23
80	205			20	245	170	230	317	40 (38)	24	20	265	140	123 (123)	80 (80)	50	447 (447)	M10 (M10)	M8	—	25
90	260			25	310	215	280	/2 332.5 /3 347.5	50 (48)	24	20	307	195	140	100	50	/2 482.5 /3 497.5	M12 (M12)	M8	39.5	35
110	310			25	360	250	320	422	60	28	23	352	225	160	120	60	602	M12	M8	36	35
120	310			27.5	365	250	350	491	60	38	23	415	225	191	120	80	691	M12	M10	—	45
140	370			35	440	290	400	/2 458.5 /3 508.0	70	38	27	423	270	185	140	110	/2 708.5 /3 758.0	M16	M10	41.4	60

AMP/F1.. - ACP/F1..																																									
		50				55				60				70				80				90				100				110				120				140			
		F1	F2	F3	F4	F1	F2	F3	F1	F2	F3	F1	F2	F3	F1	F2	F3	F1	F2	F3	F1	F2	F3	F1	F2	F3	F1	F2	F3	F1	F2	F3	F1	F2	F3						
F		120	160	200	250	160	200	250	160	200	250	160	200	250	250	300	350	250	300	350	350	450	400	350	450	400	350	450	400	350	450	400	350	450	400						
F_Q		—	—	—	—	—	—	—	—	—	—	—	—	—	—	—	—	—	—	—	—	—	—	—	—	—	—	—	—	—	—	—	—	—	—						
G(g6)		80	110	130	180	110	130	180	110	130	180	180	—	—	180	230	230	250	230	250	250	350	300	250	350	300	250	350	300	250	300	250	300	350							
R		100	130	165	215	130	165	215	130	165	215	215	—	—	215	265	265	300	265	300	300	400	350	300	400	350	300	400	350	300	350	300	350	400							
V		9	10	13	15	10	13	15	10	13	15	15	—	—	15	15	15	19	15	19	19	19*	18	19	19*	18	19	19*	18	19	19*	19*									
U		3	3.5	3.5	4	3	3.5	3.5	3	3.5	3.5	4	—	—	4	4	4	5	4	5	5	5	5	5	5	5	5	5	5	5	5	5									

* 8 trous / orificios / furos

AMF	IEC	50		55		60		70		80		90		100		110		120		140	
		Y	cMF	Y	cMF	Y	cMF	Y	cMF	Y	cMF	Y	cMF	Y	cMF	Y	cMF	Y	cMF	Y	cMF
AMP/F1../2	B5	140	206	160	233.5	160	246	200	284.5	200	298	250	313	250	347.4	250	374	250	440	300	465
		160	206	200	233.5	200	261	250	284.5	250	308	300	345	300	347.4	300	374	300	440	350	474
		200	226	250	243.5	250	271	300	284.5	300	329	350	364	350	411.4	350	438	350	482.5	400	479
		250	236	—	—	300	295	—	—	350	359	—	—	400	416.4	400	443	400	487.5	450	519
	B14	120	226	120	233.5	120	261	200	284.5	—	—	—	—	200	347.4	200	374	200	440	—	—
		140	226	140	233.5	140	261	—	—	—	—	—	—	—	—	—	—	—	—	—	—
		160	236	160	243.5	160	271	160	262	—	—	—	—	—	—	—	—	—	—	—	—
		—	—	—	—	200	295	—	—	—	—	—	—	—	—	—	—	—	—	—	—
AMP/F1../3	B5	140	206	140	228	160	246	160	254.5	200	298	200	331	200	340.4	200	367	200	423	250	457
		160	206	160	228	200	261	200	269.5	250	308	250	338.5	250	350.4	250	377	250	445	300	457
		200	226	200	238	250	271	250	279.5	—	—	—	—	300	370.4	300	397	300	452	350	499.5
		—	—	—	—	—	—	—	—	—	—	—	—	—	—	—	—	—	—	400	504.5
	B14	—	—	—	—	—	—	—	—	—	—	—	—	—	—	—	—	—	—	450	513.5
		120	226	120	238	120	261	120	269.5	—	—	—	—	—	—	—	—	—	—	—	—
		140	226	140	238	140	261	140	269.5	—	—	—	—	—	—	—	—	—	—	200	457
		—	—	—	—	160	271	160	279.5	—	—	—	—	—	—	—	—	—	—	—	—

ACP/F1.	50	55	60	70	80	90
	cCP					
ACP/F1../2	167	—	202	—	241	—
ACP/F1../3	167	189	202	210.5	241	271

Les dimensions cMP se réfèrent aux combinaisons arbre/bride B5 et B14 standard.
Pour les dimensions relatives aux combinaisons arbre/bride sur demande, contacter notre Service Technique.

Las dimensiones cMP se refieren a las combinaciones eje/brida B5 y B14, estándar.
Para las dimensiones relativas a combinaciones eje/brida sobre pedido, contactar nuestro servicio técnico.

As dimensões cMP referem-se às combinações eixo/flange B5 e B14, standard.
Para dimensões sob encomenda de combinações eixo/flange, contacte o nos. serviço técnico.



1.9 Languettes

1.9 Chavetas

1.9 Lingüetas

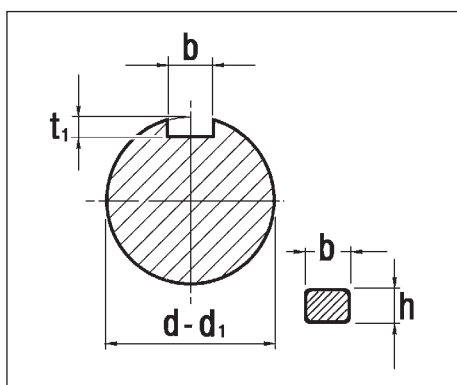

Arbre côté entrée
Eje entrada
Eixo entrada

Arbre côté sortie
Eje salida
Eixo saída

d_1	$b \times h$	t_1
16	5 x 5	3.0
19	6 x 6	3.5
24	8 x 7	4.0
28	8 x 7	4.0

d	$b \times h$	t_1
11	4 x 4	2.5
14	5 x 5	3.0
16	5 x 5	3.0
19	6 x 6	3.5
20	6 x 6	3.5
24	8 x 7	4.0
25	8 x 7	4.0
28	8 x 7	4.0
30	8 x 7	4.0
35	10 x 8	5.0
38	10 x 8	5.0
40	12 x 8	5.0
48	14 x 9	5.5
50	14 x 9	5.5
60	18 x 11	7.0
70	20 x 12	7.5